



Horizontal Sliding Walls

Technical brochure 2020

HSW EASY Safe
FSW EASY Safe
HSW-GP
HSW-R

dormakaba 

Content

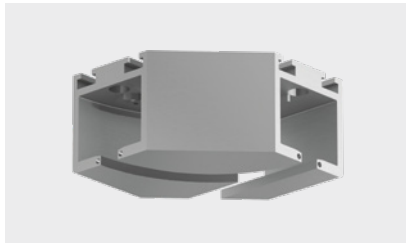

4 **HSW Support and guide elements**

- 6 Stacking
- 8 Example stacking arrangements
- 13 Stacking arrangements calculation
- 16 Track rails
- 22 Substructure



32 **Panel systems**

- 34 General information
- 38 HSW EASY Safe
- 60 FSW EASY Safe
- 70 HSW-GP
- 74 HSW-R



84 **Accessories**

- 86 Vertical seals – overview
- 88 Vertical sealing profiles – general preparation
- 89 Vertical sealing profiles – panel types
- 96 Handle bars, door knobs and recessed pull grips



104 **General information**

- 106 Measuring Up
- 107 General information
- 109 Safety-related information

Content

Support and Guide Elements

06 **Stacking arrangements**

16 **Track rails and modules**

22 **Substructure**



Support and Guide Elements



The right stacking arrangement for any situation

Perfect parking every time

Existing structures or unusual layouts often require special solutions, particularly in the design of the stacking area. dormakaba HSW systems can be parked in a range of different positions. The stack of panels can be aligned parallel or square to the frontage, be readily visible for effect or hidden behind columns etc. Another possibility is that of parking the system in line

but out of the way, whether behind a wall or in a niche (see also pages 8). The panels can also perform certain functions when the frontage is open, such as providing the sides of internal store windows and showcases, or, if provided with the appropriate printing on the glass, for adding artistic value to a wall. The following pages show some system solutions devised in answer to a wide range of different problems.



Panels transverse to travel direction

Panels stacked 90° angle transverse to travel direction

Product description

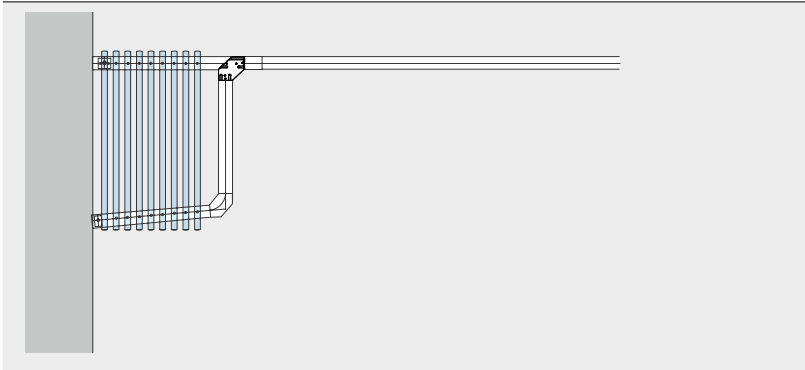

Standard stacking arrangement.

With pivoting end panel, single- or double-action, to use as possible access leaf (left or right, or left and right).

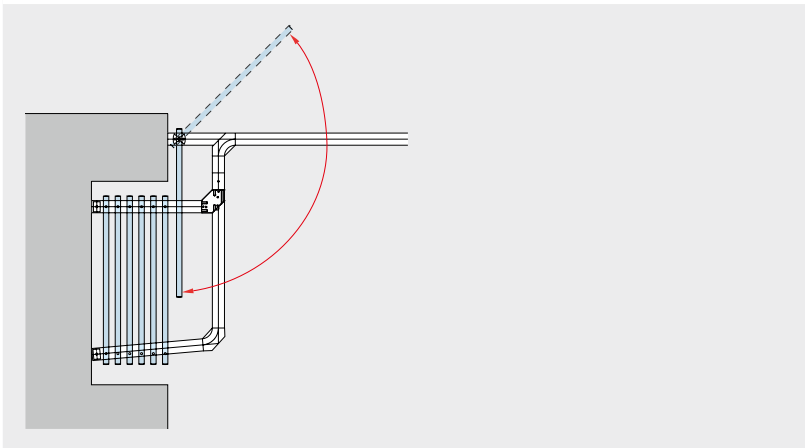

Niche stacking.

With pivoting end panel, single- or double-action, to use as possible access leaf (left or right, or left and right).

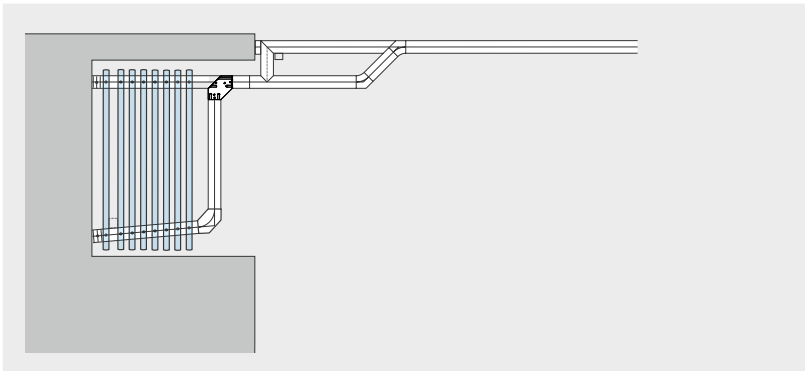

Stacking with reshuffle bypass

(without pivoting end panel). Behind wall projection/ fixed side panel (Left or right, or left and right).

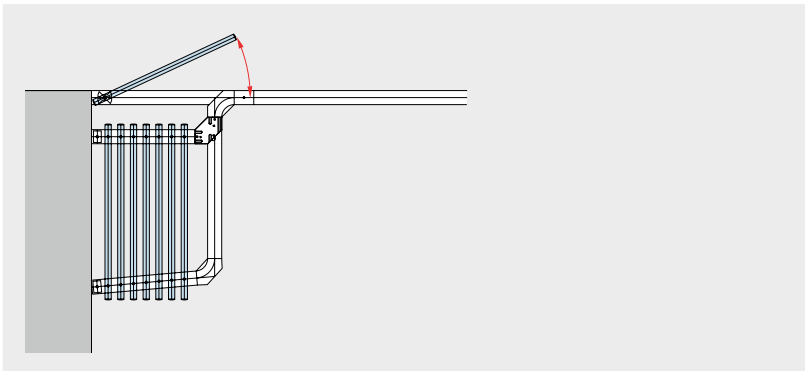

Stacking behind pivoting end panel,

single-action or double-action (Left or right, or left and right).

Product description

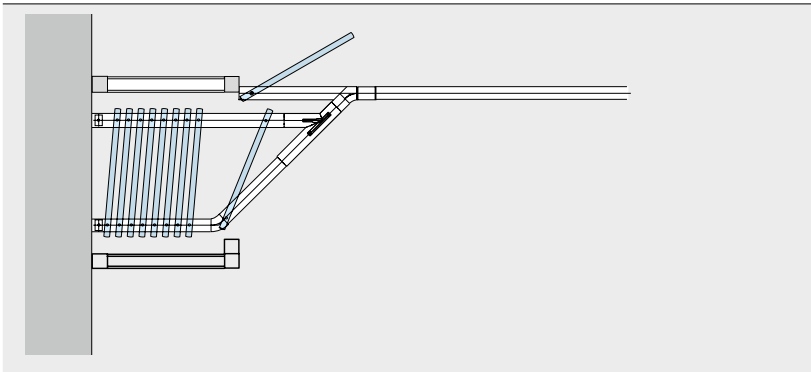

Stacking in a box or niche, behind pivoting end panel,
 double-action
 Sliding panels only, around 135° offset
 (left or right, or left and right).

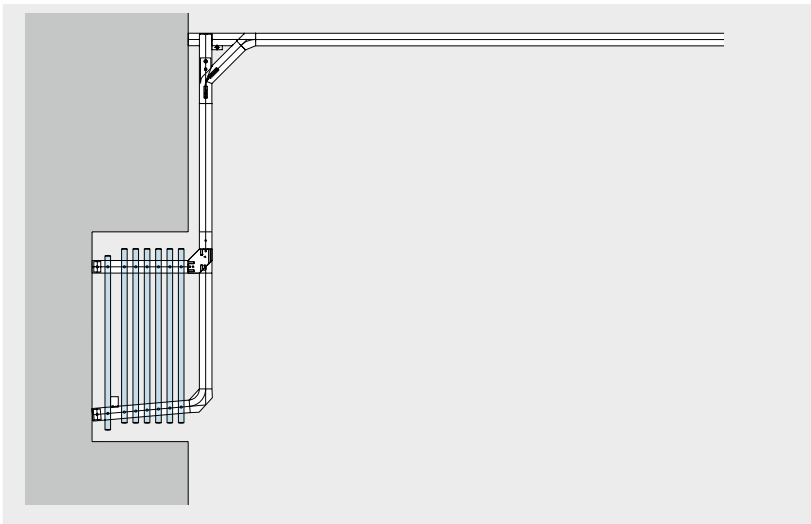

Stacking in a box/pocket.
 For sliding panels or double-action sliding panels
 (left or right, or left and right).

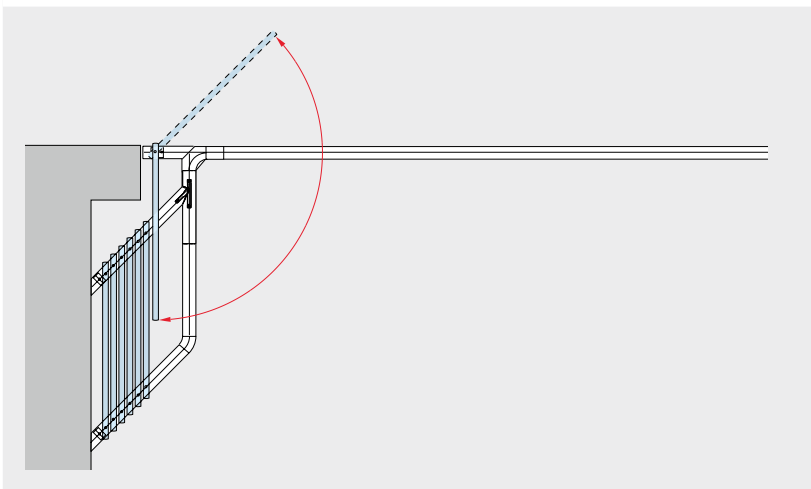

Stacking behind column.
Stacking legs at 135° angle.
 With pivoting end panel, double-action, to use as possible access leaf
 (left or right, or left and right).

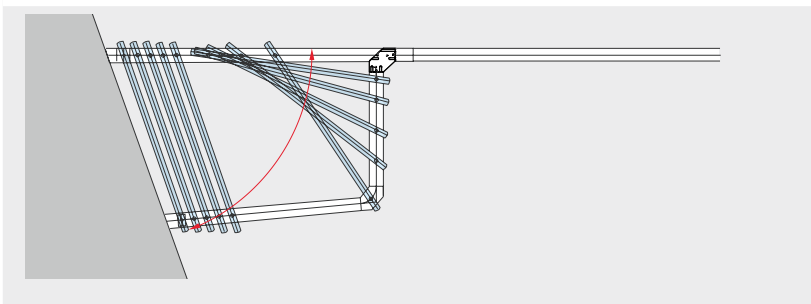

Stacking at acute angle.
 All panels brought into position with rear track roller.

Panels parallel to travel direction

Product description

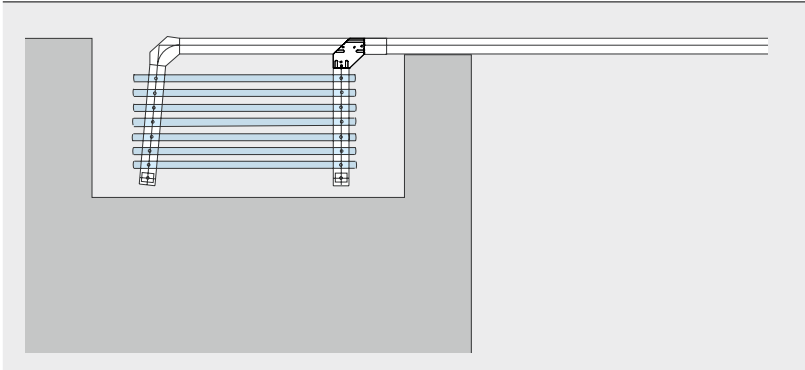

Stacking in a niche, outer stacking leg at 95° angle

for small number of panels (up to 6)
(left or right, or left and right).

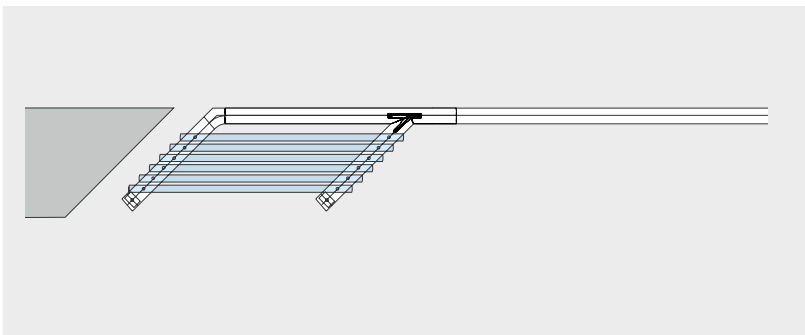

Stacking legs at 135° angle

(left or right, or left and right).

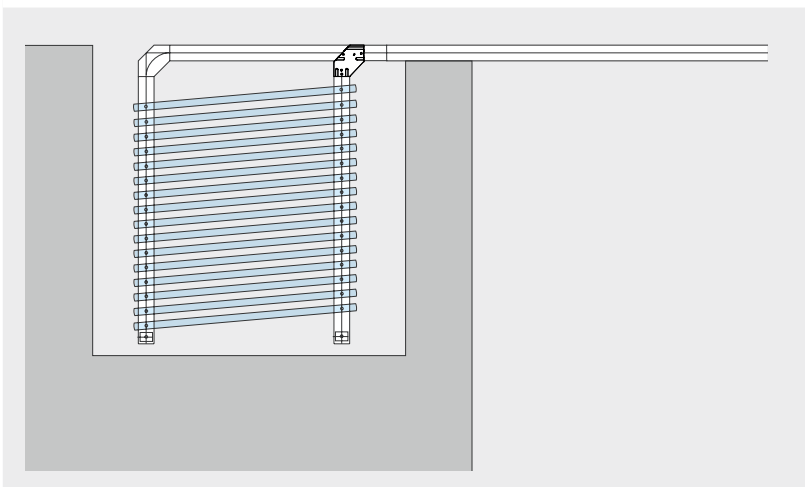

Stacking legs at 90° angle

for large number of panels (more than 6)
(left or right, or left and right).

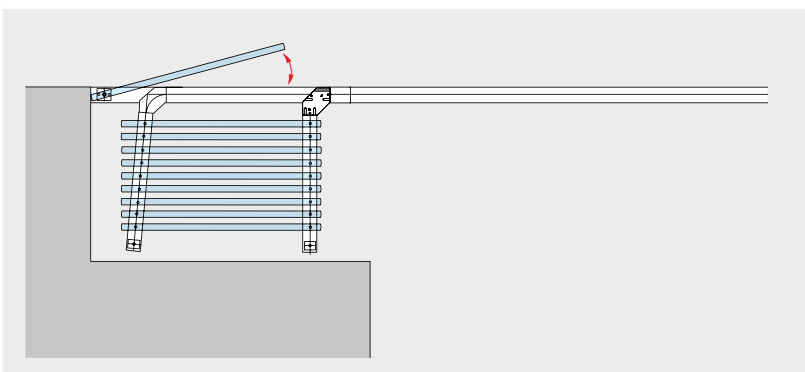

Stacking behind pivoting end panel

Outer stacking leg at 95°
(left or right, or left and right).

Product description

Stacking offset in niche
with sliding folding panel as
wall connection stacking legs at 90°
(left or right, or left and right).

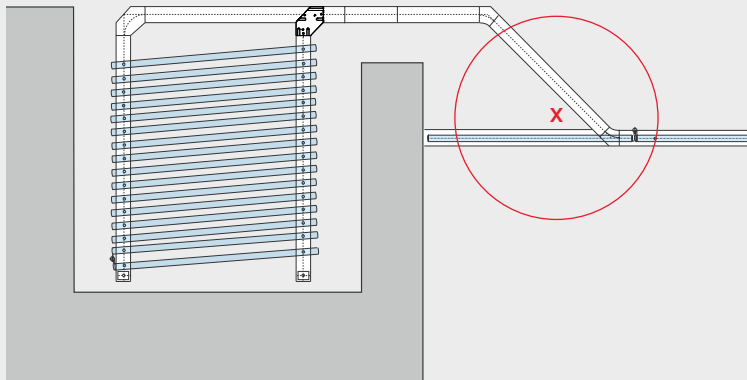

Detail X
Sliding folding panel in closed wall.

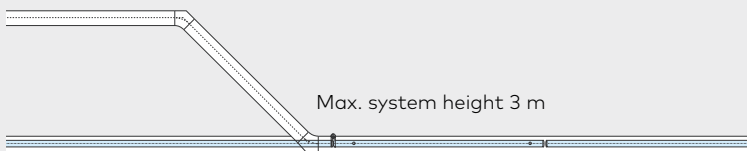

Sliding folding panel ready for sliding into stacking area.

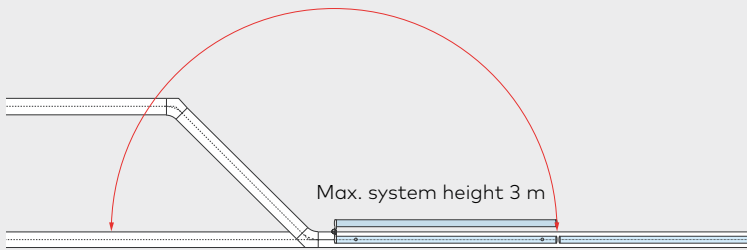

Stacking behind fixed panels
(left or right, or left and right).

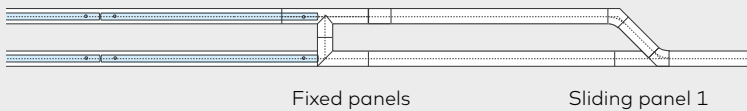

Stacking offset, beyond offset hung pivoting end panel, single- or double-action
(left or right, or left and right).

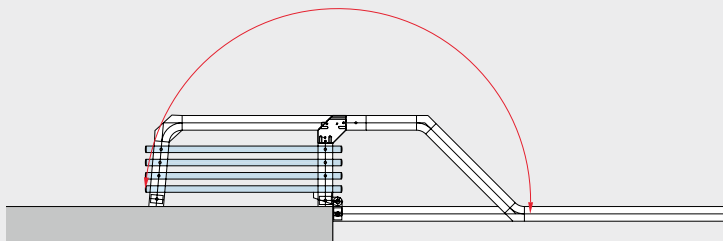

Special stacking arrangements

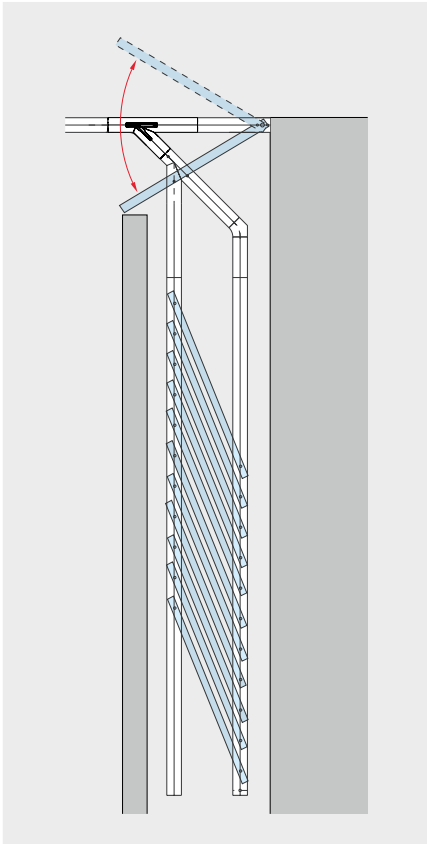

Stacking at the wall in closed compartment behind pivoting end panel, single- or double-action

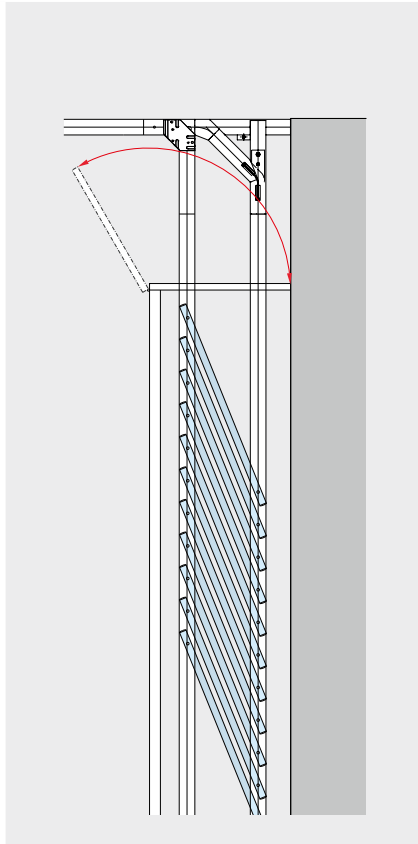

Stacking at the wall in closed compartment without pivoting end panel, single- or double-action

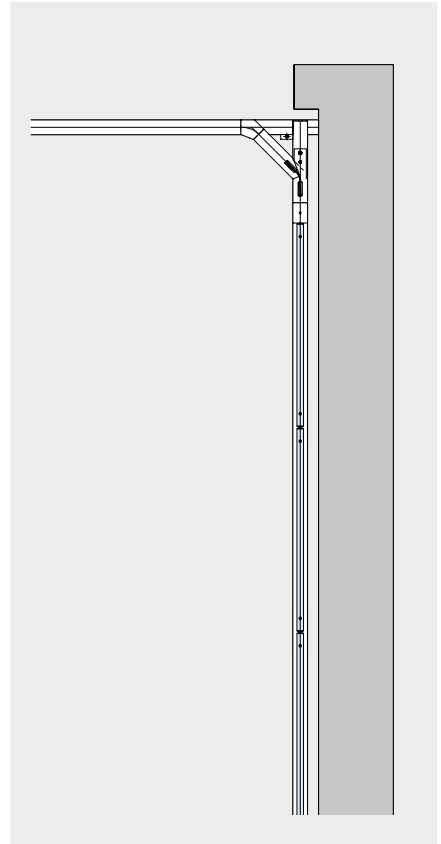

Stacking in front of 90° wall with reshuffle bypass



Stacking panels of varying width.



Stacking with one stacking leg for sliding panels in front of the pivoting end panel, single- or double-action, on each side (2 pivoting end panels/2 sliding panels).

Stacking arrangement calculations

Panels stacked 90° angle transverse to travel direction (left or right, or left and right)

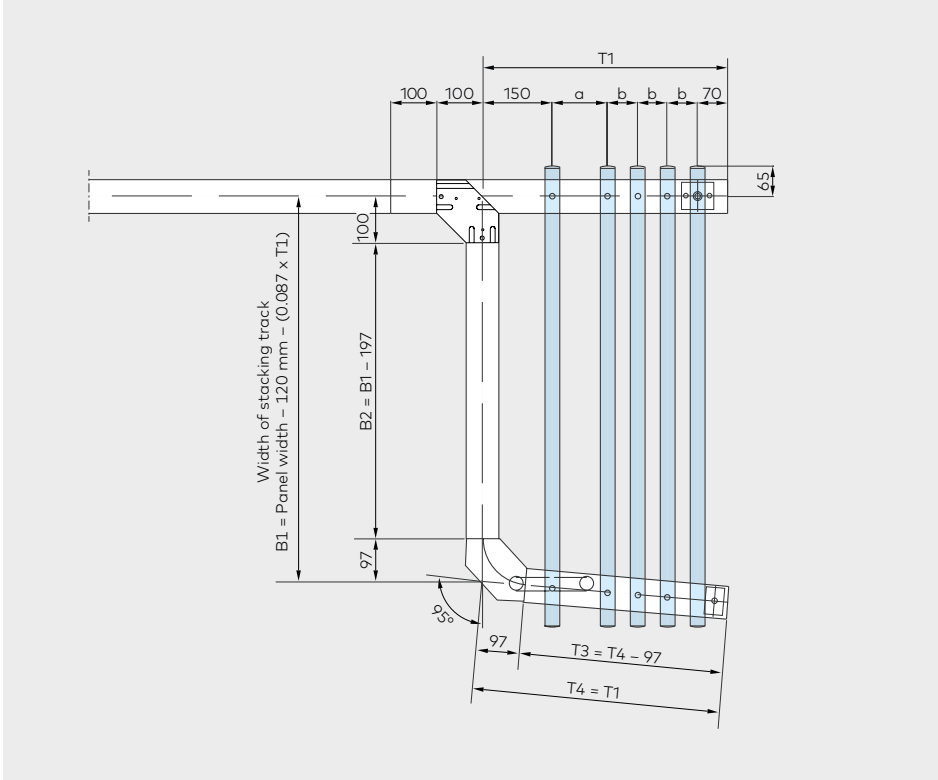

a = depending on pull handle depth
 b = 65 mm for HSW EASY Safe
 80 mm for HSW-R

HSW-GP cannot be configured with a 95° junction.

Stacking legs at 135° angle (left or right, or left and right).

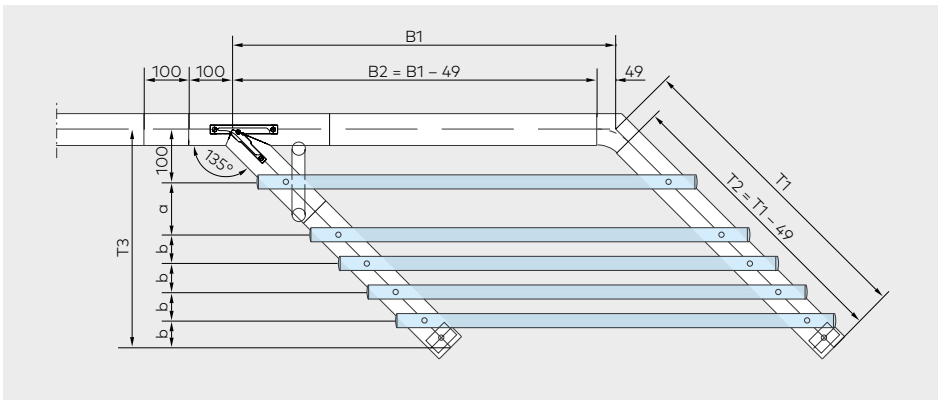

a = depending on pull handle depth
 b = 65 mm for HSW EASY Safe
 80 mm for HSW-GP and HSW-R

$B1 = \text{Panel width} - 130 \text{ mm}$
 $T1 = T3 \times 1,414 \text{ mm}$

Stacking in a niche, outer stacking leg at 95° angle for small number of panels (up to 6) (left or right, or left and right).

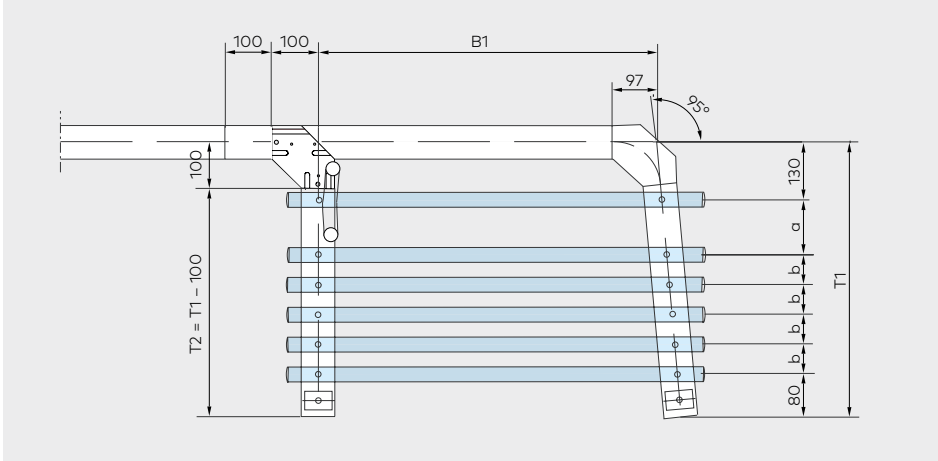

a = depending on pull handle depth
 b = 65 mm for HSW EASY Safe
 80 mm for HSW-R

$$B1 = \text{Panel width} - 130 \text{ mm} - ((T1 - 80) \times 0.087)$$

HSW-GP cannot be configured with a 95° junction.

Stacking legs at 90° angle for large number of panels (left or right, or left and right).

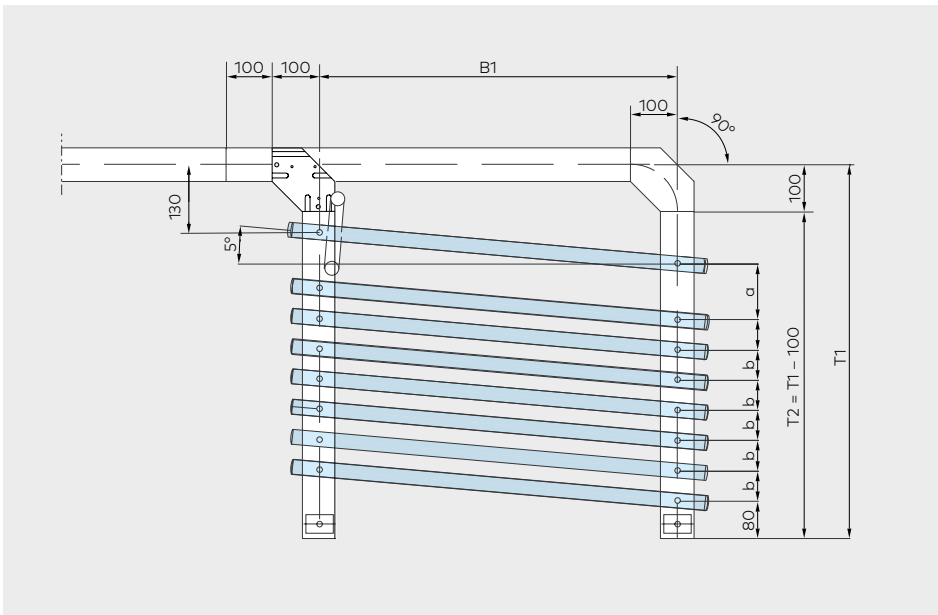

a = depending on pull handle depth
 b = 65 mm for HSW EASY Safe
 80 mm for HSW-GP and HSW-R

$$B1 = \text{Panel width} - 134 \text{ mm}$$

Space for your notes

Simple, secure and removable connections

Plug connection of tracks and modules

To provide fast, easy and flexible installation of the track rail sections and the modules it is a considerable advantage when all parts are delivered unwelded. The special HSW track rail design with two parallel channels at the top (suitable for M 10 screws) simplifies the work on site.

- The single track rail sections and modules are connected to each other by special clamp inserts fitted in the provided channels, delivering secure connection.
- If necessary even adjustment cuts of track sections can be done on site.
- In the lower part of the track rails additional pins provide smooth and even passage for the roller carriers.
- Even the stacking construction is fitted together and connected to the frontage track rail in the same way.
- As an option parts of the stacking construction can be delivered pre-mounted.
- The segmentation is realized by mitre cuts and welded connections within single track rail sections as supplied condition. On site the adjacent track rail section then can easily be fitted in a straight line by clamp inserts and pins.

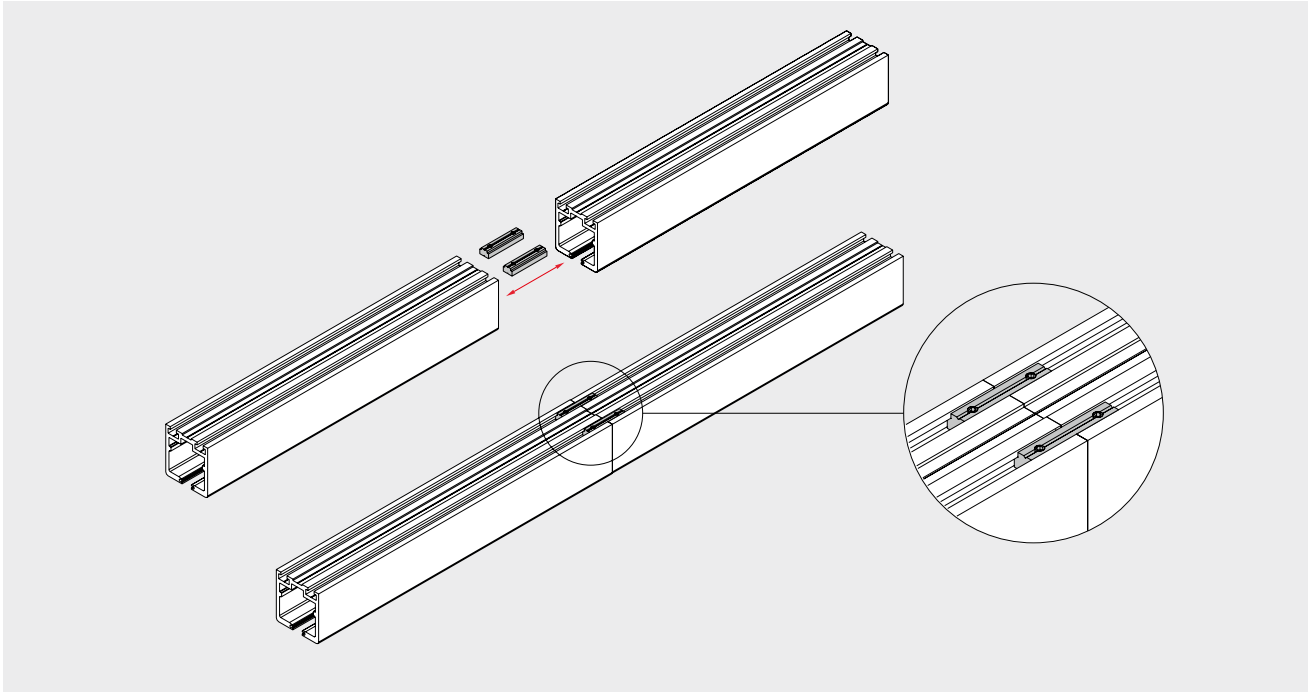
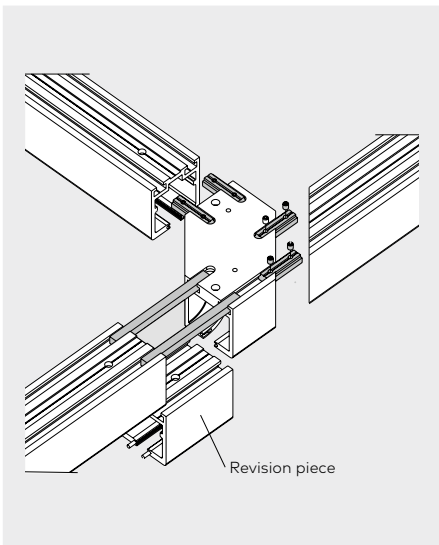
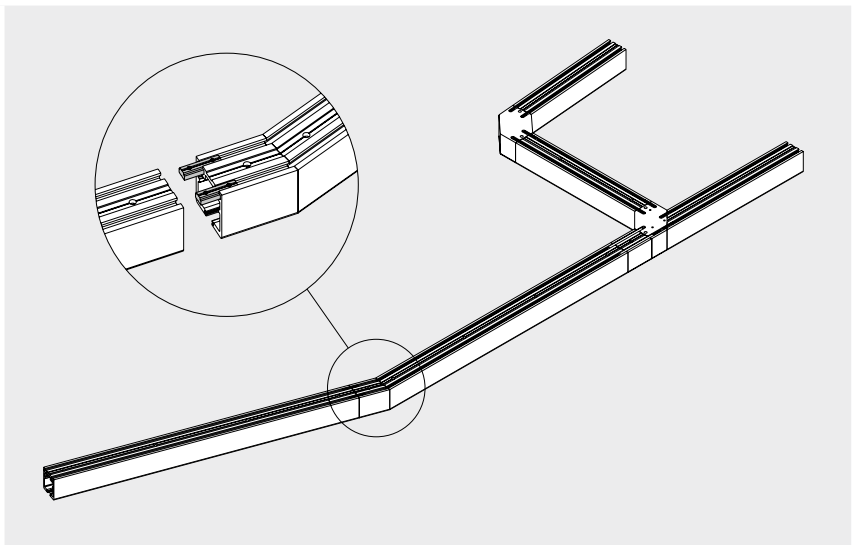
Single track rail section**Stacking construction****Segmented track rail section**

Flexible and stable

Horizontal sliding walls can be constructed in a wide range of different configurations to suit the site of installation, prevailing structural conditions and the planning concept. With dormakaba HSW systems, a variety of designs can be implemented with ease. Straight and segmented track rails can be combined to produce virtually any serpentine shape required. The track rails in the form of hollow sections combine all the virtues of light weight, stability and torsional stiffness. And when combined with the HSW substructure, installation becomes even easier. Flexibility and stability mean that even unusual system configurations can be implemented without problem to give maximum functional reliability.

Straight track rail

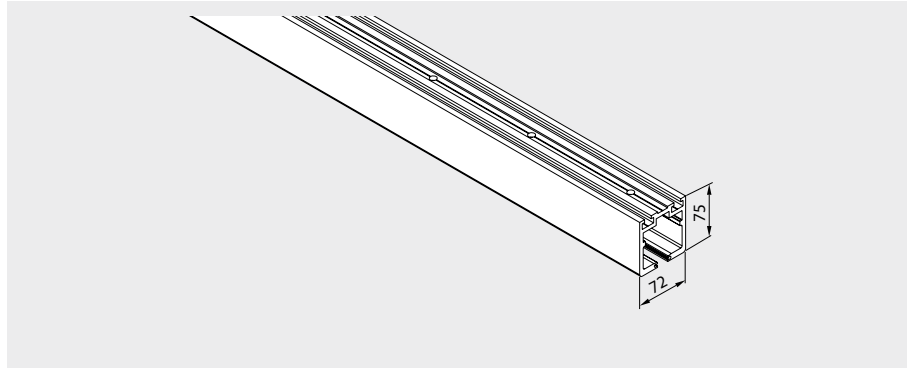

Track rail at stacking area

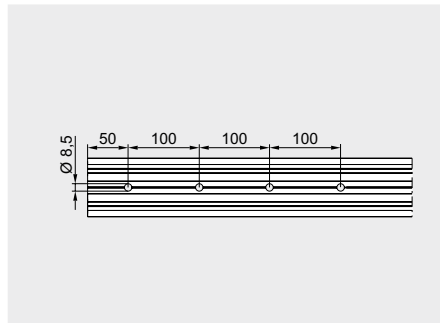

Track rail at assembly frontage

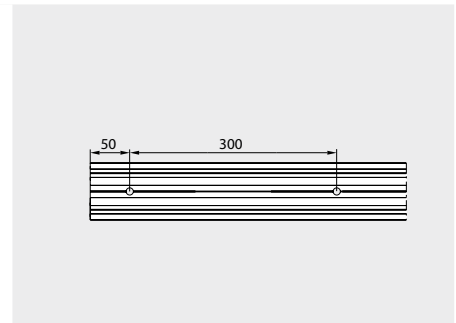

90° T-piece

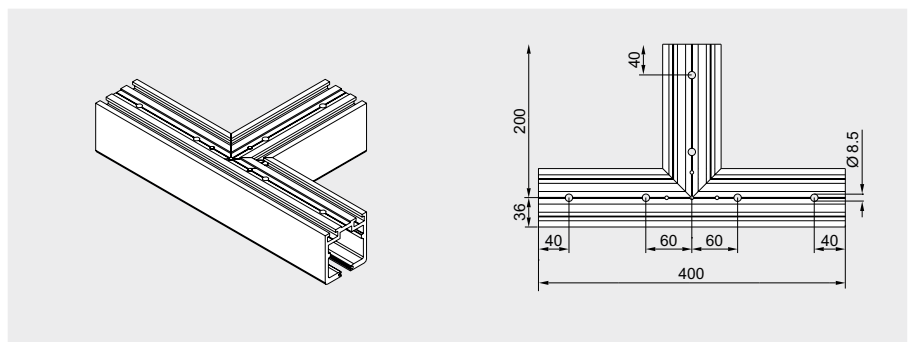

135° T-piece

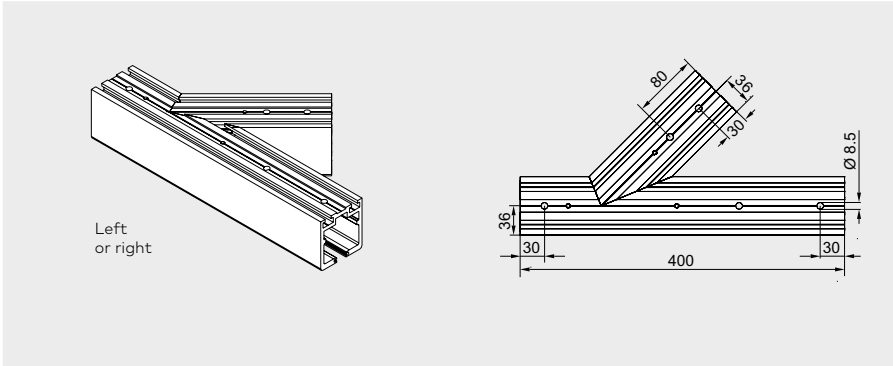

Straight track rail

For a straight-line system configuration, a drill hole interval of 300 mm in the track rail is sufficient, while the stacking area requires an interval of 100 mm. Where the track assumes an angle of 161 – 179°, the track rail is mitred, while at angles between 90 and 160°, a segment is incorporated. The standard modules available are indicated in the adjacent illustrations.

90° L-piece

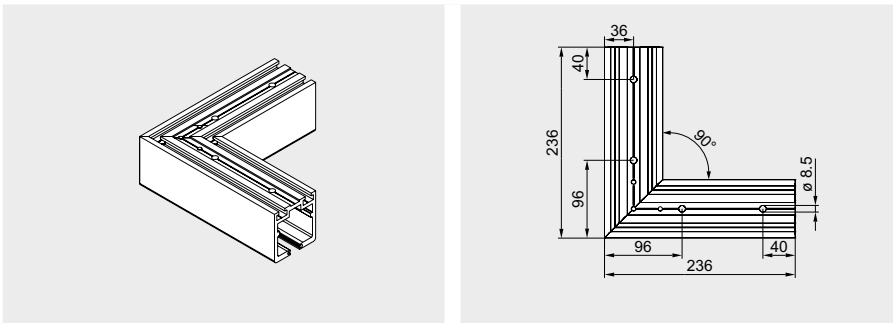

**Module 07/09
for 90°/95° angle**

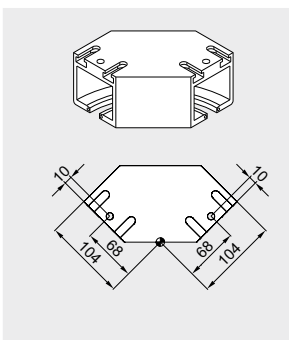

**Module 06
for 45° angle**

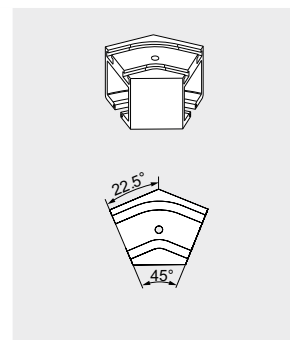

**Module 04/05
90° angle left/right**

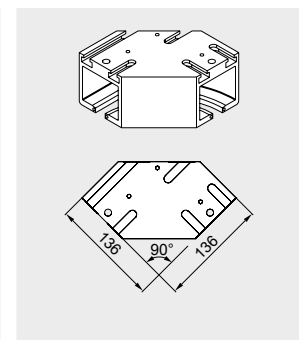

Segmented track rail

With the segmented track rail, it is possible to implement the dormakaba HSW as a polygonal partition or frontage. In so doing, it is essential to note the following requirements:

- The panel width and segment chord length must be properly coordinated;
- Segment panels are provided at the bottom with locks or face-mounted floor bolts
- It is important to ensure that the opening sweep of single-action and double-action panels does not give rise to collisions.

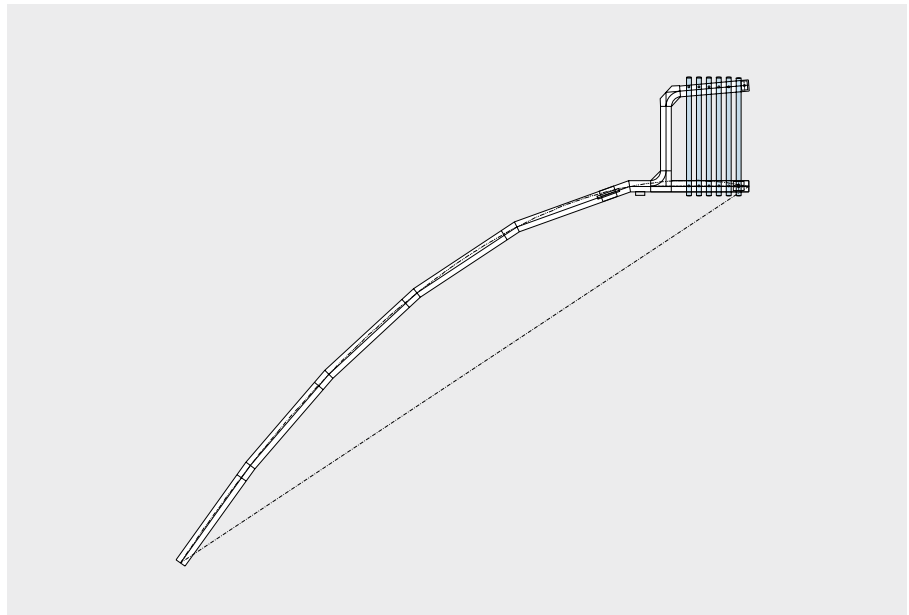

Curved track rail

The curved track rail is offered for installing a rounded track rail of a DORMA HSW system. The following technical conditions are applicable here:

- Only sliding panels can be used in the curved track rail area
- The curved track rail must be foregone in the stacking area
- A top locking device cannot be installed. Each panel gets two front locking devices
- In case of installation in the stacking area, a 100 mm long piece of straight track rail is required
- Tails of the curved installation can be designed with standard modules
- Min. bending radius is 3,500 mm (smaller radius upon request)
- If elliptic system configurations are required, it is decided in each individual case. Drawings are required for this
- Curve start and curve end are principally performed with a 90° saw cut (rotary saw cut)

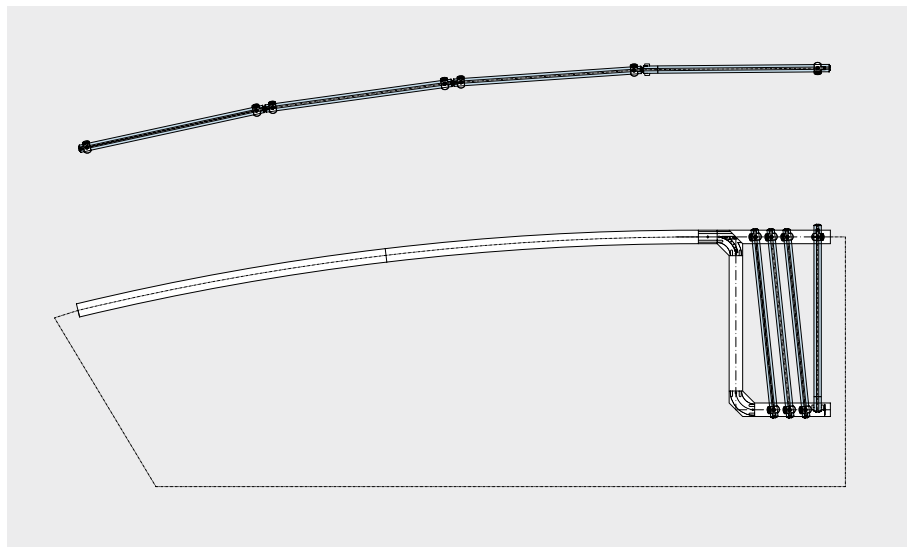

Space for your notes

Substructure – the system

Solutions

Installing a horizontal sliding wall system invariably requires a certain set of structural conditions to be established. The system will need to be precisely aligned vertically – usually sub-sequent to installation – as well as being exactly configured and securely located.

Because dormakaba HSW systems do not use floor-level supports and floor tracks, the system requirements and all their technical properties must be taken into account when designing the substructure and its incorporation within the ceiling. This often very costly planning process is normally undertaken by the fabricator as the installation company, and alongside the calculations there are many individual structural and installation procedures involved.

The new dormakaba substructure system is of modular construction and is designed to significantly reduce on-site installation cost and time. This concept also offers the particular flexibility required to overcome structural constraints, such as the presence of air conditioning shafts or pre-existing electrical systems in the ceiling.

System design

The dormakaba substructure consists primarily of the following components: substructure profile with modules for branching to the stacking area, threaded rods for suspension of the profile(s), and standard square section tubes with appropriate fixings and ceiling brackets for bracing and stiffening the construction.

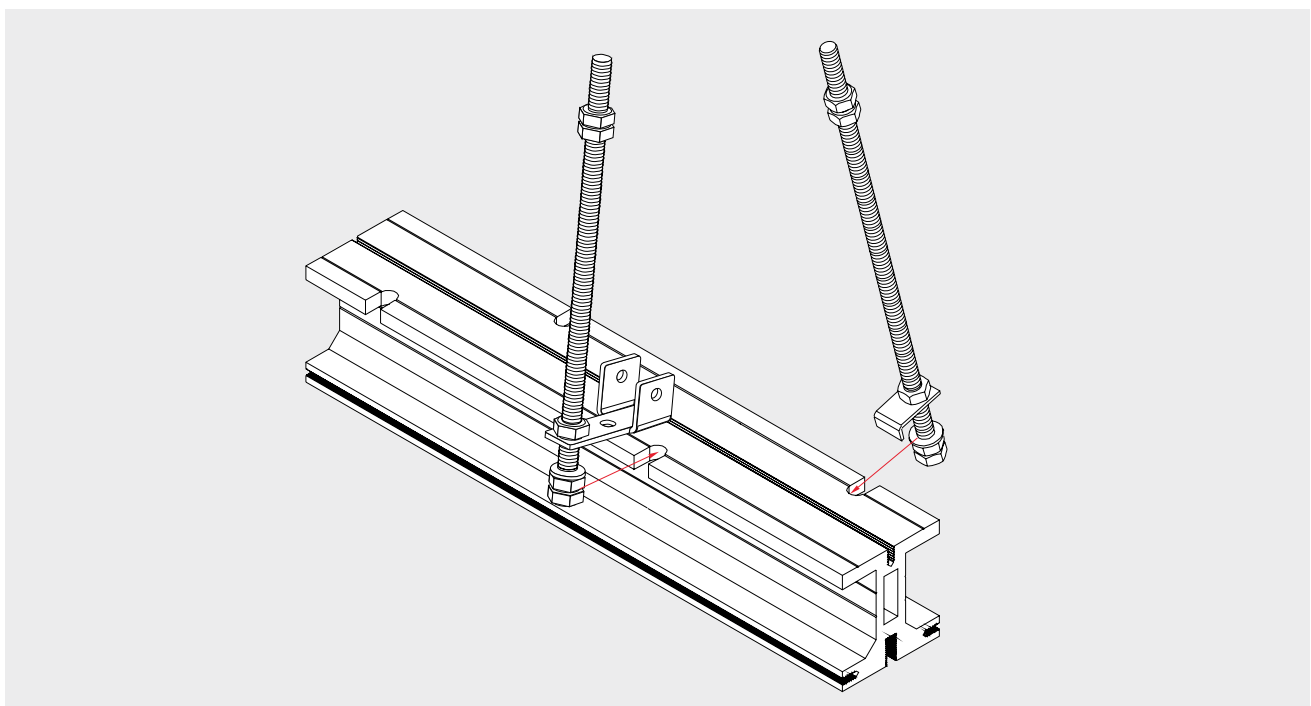
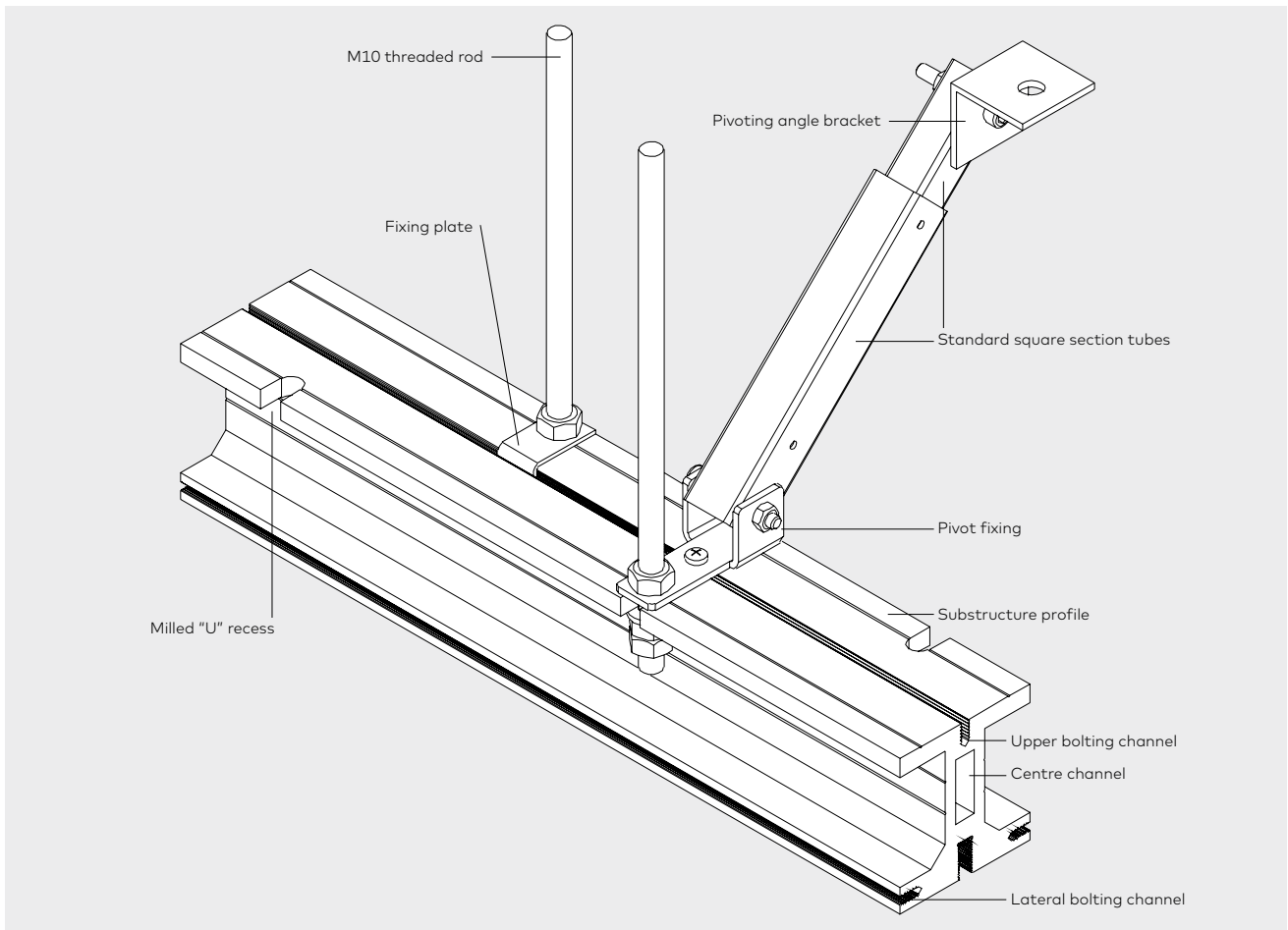

Safety and flexibility

The dormakaba substructure has been developed on the basis of extensive practical experience of the requirements involved in this kind of system. Consequently, the profile incorporates features that greatly facilitate installation and ensure that pre-existing structural factors can be accommodated with maximum flexibility.

Various bolting channels run the whole length of the profile, allowing bolts to be inserted easily at any location within the system configuration. So there is no need for pre-drilling and thread cutting in order to mount the track rails onto the substructure.

Bolted connections can be made directly through the lower bolting channel. The problem of removing drillings and filings from the track rails is thus also a thing of the past.

Bolting channels on both sides of the profile can be used e.g. for fixing the brackets needed for attaching the ceiling retention elements. In addition, centering grooves on all main profile surfaces facilitate overhead drilling, e.g. for accessory attachment. Welding brackets designed for bolting onto the profile provide another option, allowing the dormakaba system to be utilised for additional customer-specific applications.

The substructure profile is suspended from threaded rods. These are first placed in the U-recesses using fixing plates that lock into the upper bolting channel. Each pair of threaded rods is regarded as constituting one suspension point. Here again the system remains exceptionally flexible: the staggered U-recesses positioned at intervals of 100 mm enhance the ability of the system to accommodate structural constraints. Depending on the weight of the system and the permitted deflection, it is possible to span a distance of up to 2,100 mm between two suspension points.

The centre channel can be fitted with two flat aluminium bars to provide additional rigidity in the area of butt joints between profiles. In this case it is possible to dispense with the dual suspension arrangement – with one suspension point either side of the joint – which is otherwise necessary. So existing building installations of all types can be effectively bypassed.

Once the substructure has been installed, the HSW system is vertically aligned and fixed directly via the threaded rods. Subsequent adjustments, e.g. after the building has settled into its foundations, can also be carried out by the same means.

The standard square section tubes offer extra safety, especially where the sliding panels deviate from a straight line. Panel sway must be effectively countered by the structural design adopted at such locations.

Diagonal struts that counteract the pressure load stabilise the system in the area of the stacked panels. The telescopic square section tubes are connected as additional bracing elements (struts) to the substructure by a pivot fixing. The struts are bolted to the ceiling using the appropriate angle brackets.

The modular design of the dormakaba substructure is precisely matched to the modules of the dormakaba HSW track rail. The structural elements can be mixed and matched as desired with the result that a small number of component types is sufficient to create a complex, flexible system that conforms fully to all safety requirements.

A drawing of the required sub-structure can be requested from dormakaba to supplement the HSW system drawing always supplied with the quotation.

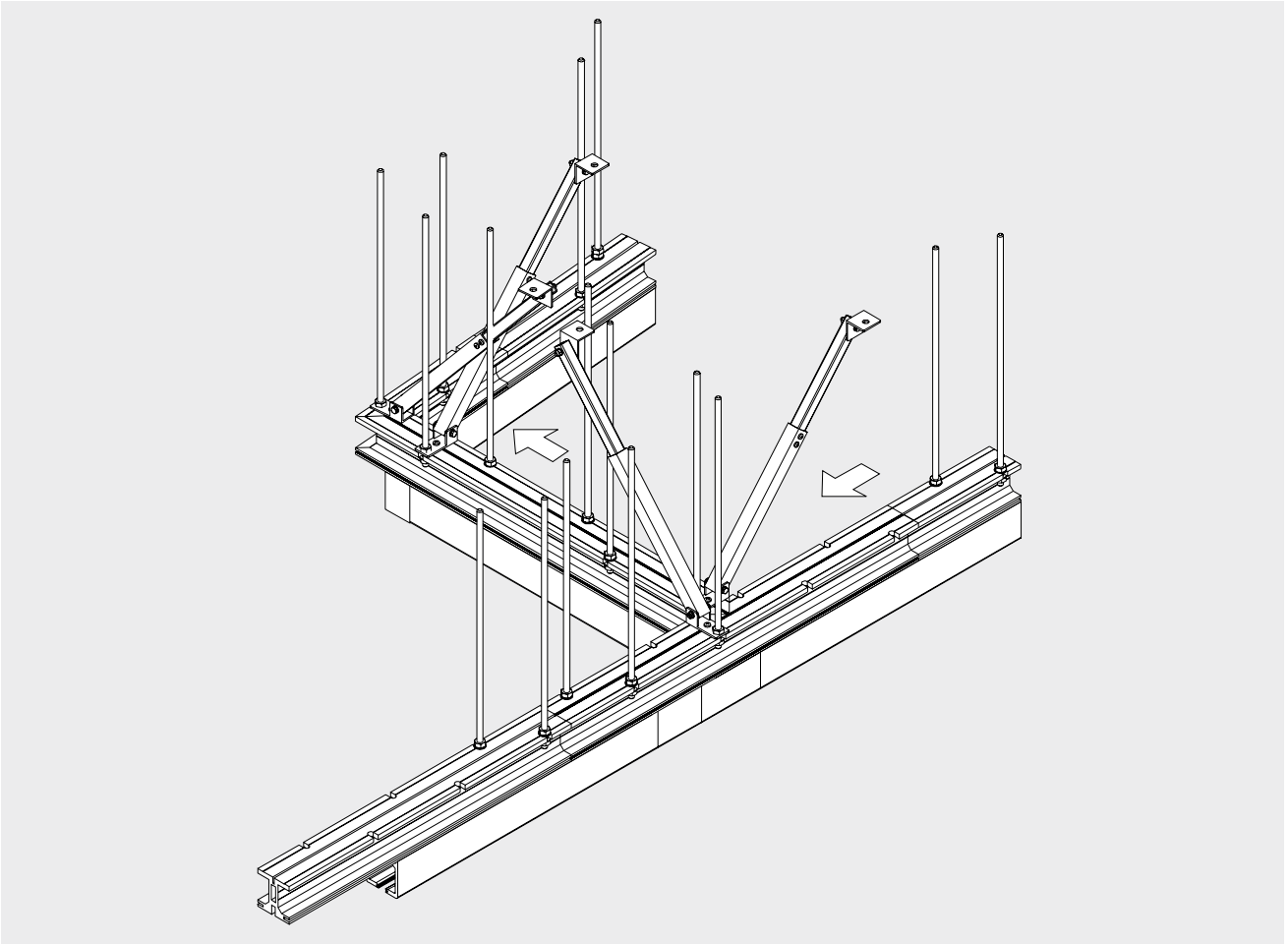

The forces (shown by arrows) that occur during opening and closing of the sliding wall system must be absorbed by appropriately located bracing elements.

Planning details

Calculating the suspension intervals

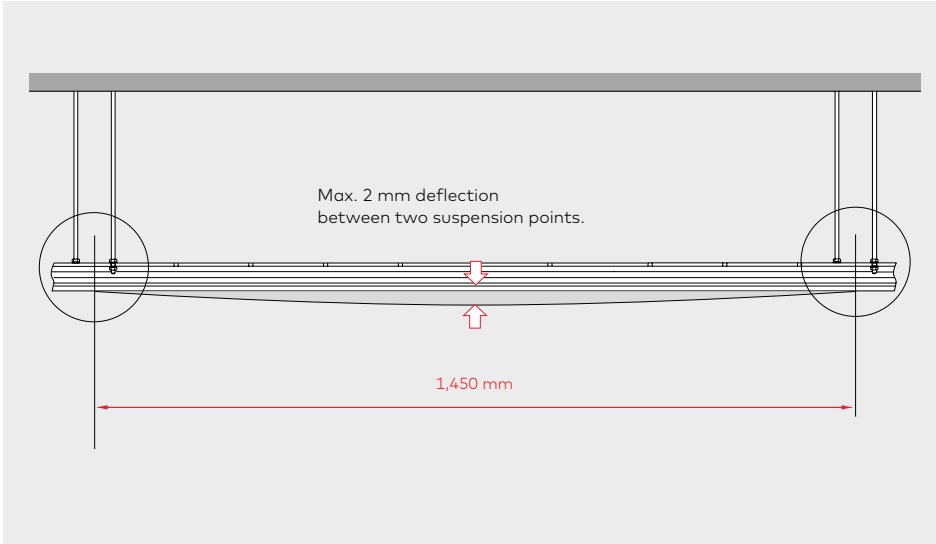

With a maximum load (panel weight) of 150 kg/m and a permitted deflection of the substructure with track rail of 2 mm, the interval between two suspension points must be no greater than 1,450 mm. The table below shows other values for different loads.

In order to prevent system sway, every second suspension point must be reinforced by a strut. The substructure profile ends (travel path and stacking area) should ideally be directly connected to the masonry or to existing structural members.

Illustrative example of load values

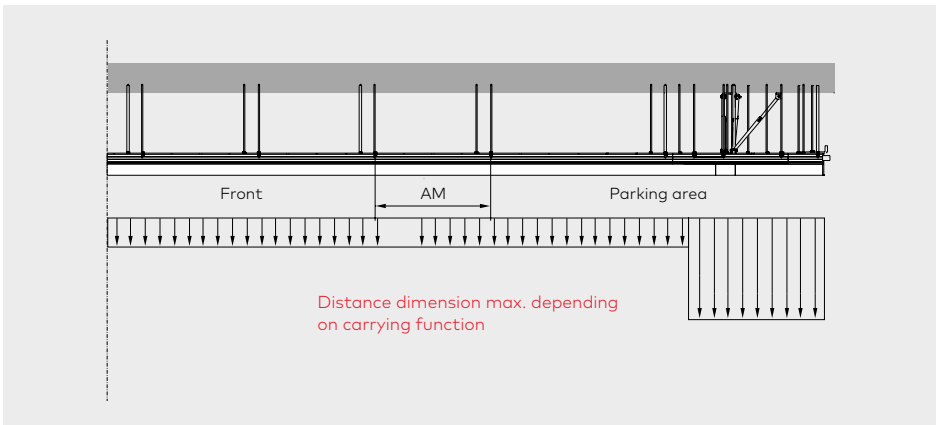

HSW EASY Safe characteristic values

Formula for calculating the:
 Glazing height
 = system height – 309 mm
 = panel height – 193 mm
 Glazing weight
 Glass 10 mm = 25.00 kg/m²
 Glass 12 mm = 30.00 kg/m²
 Door rail weight
 Aluminium = 12.00 kg/m
 Brass = 14.50 kg/m
 Stainl. steel = 13.25 kg/m

Example system

HSW EASY Safe system in stainless steel
 System height 3.5 m
 Glazing thickness 12 mm

Calculation

Load
 = glazing weight x glazing height + door track weight
 = 30 kg/m² x (3.5 m – 0.309 m)
 + 13,25 kg/m
 = 30 kg/m² x 3.191 m
 + 13.25 kg/m
 = 108.98 kg/m

F	AM
60 kg/m	2,000 mm
75 kg/m	1,900 mm
105 kg/m	1,700 mm
135 kg/m	1,600 mm
150 kg/m	1,400 mm

F = Force
 AM = Distance dimension

Force example:
 The distance dimension of
 108.98 kg/m = 1,700 mm

Stacking area design

View from below

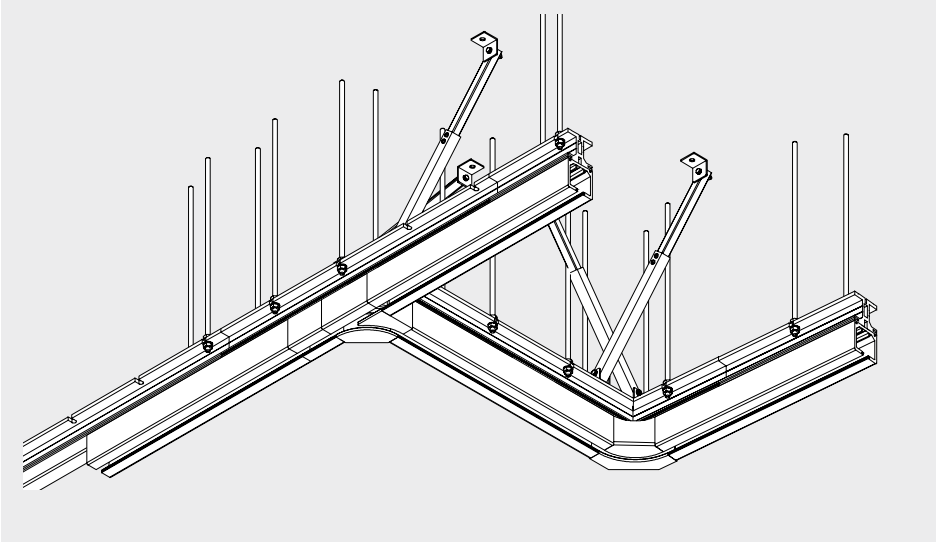

The construction of the stacking area, assembled from substructure and track rail modules, provides a good illustration of how this well-designed system can be utilised. The individual components are coordinated to ensure safe integration. Joints in the substructure are offset to those in the track rails so that individual joints coincide with continuous material in all cases.

Provided that the track rails are adequately bolted to the substructure, gaps of up to 40 cm measured from one suspension point to the next are permitted in the substructure.

View from below

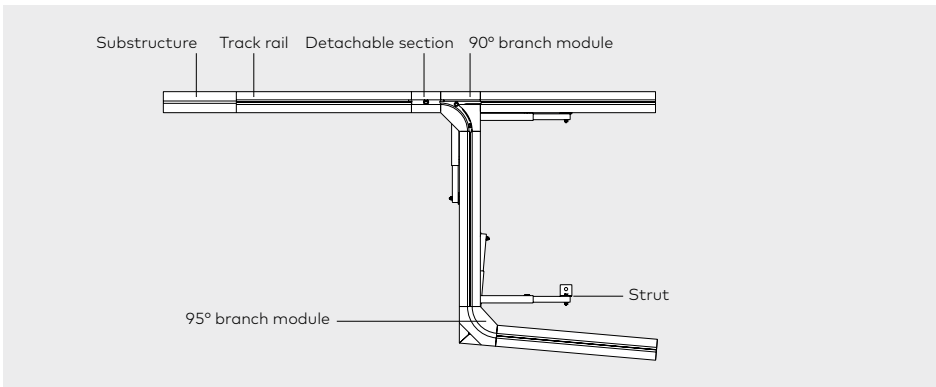

View from above

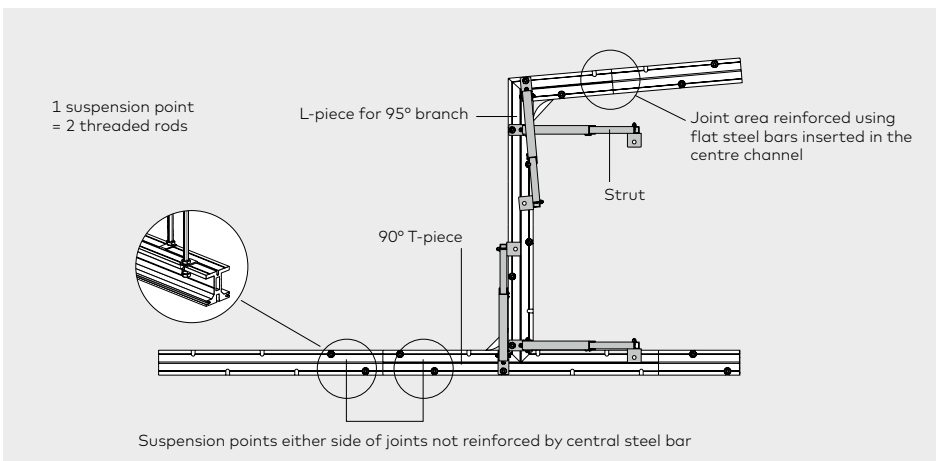

Joints reinforced by central steel bar only require one local suspension point.

Variants of connection/details

Substructure profile

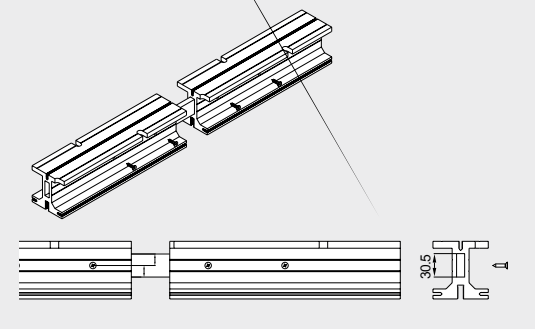
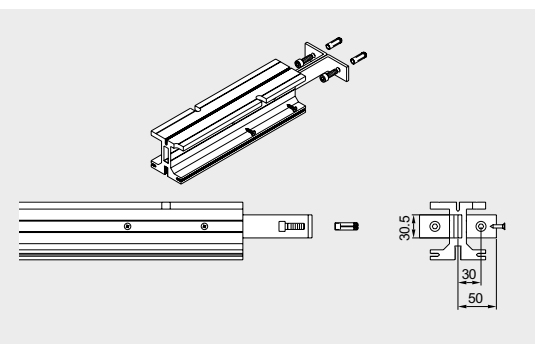
	Product description	Art. No.
	<p>Profile connection with connection lug.</p>	<p>8.15.442.001.40</p>
	<p>Wall connection with angled connection lugs. Bending of connection lug on site according to need.</p>	<p>8.15.442.001.40</p>

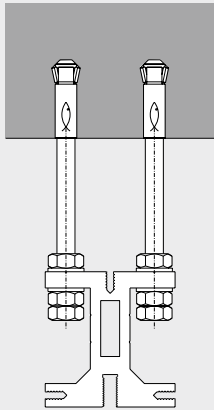
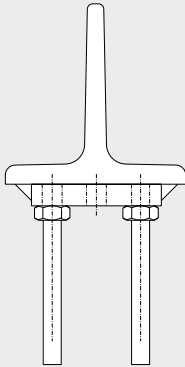
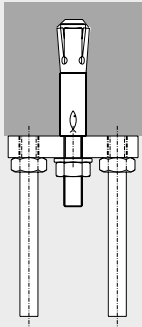
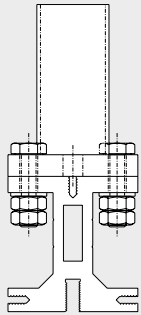
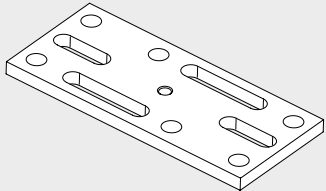
		Product description	Art. No.
<p>Direct connection to ceiling</p> 	<p>Welding connection to steel girder</p> 	<p>Connection opportunities to existing bearing structure like ceilings, balks, steel girder by dint of adapter plate.</p>	<p>8.15.435.001.40</p>
<p>Flexible connection to ceiling</p> 	<p>Connection to steel construction</p> 		
			

Component parts, accessories

Component parts	Product description	Art. No.
01	Pivoting angle bracket	815.437.001.40
02	Fixing plate	815.434.001.40
03	Pivot fixing	815.436.001.40
04	Adapter plat	840.212.000.99
05	Basic substructure profile, stock length 6,000 mm	815.658.000.99
	Fixed length	815.659.000.99
Component parts	CSN	
A	Threaded rod M10 x 1,000	800.01.470.3.30
B	Hex nut DIN 439-2 M10	800.03.001.3.30
C	Washer ISO 7089-10	800.04.009.3.30
D	Hex nut DIN 934-M6	800.03.005.3.30
E	Hex socket screw DIN 933-M6x35	800.01.337.3.30
F	Telescopic strut top section, square section tube, galvanised steel 20x20x2	800.16.025.4.32
G	Drilling screw DIN 7504 ST4 8 x 16	800.01.286.3.30
H	Telescopic strut bottom section, square section tube, galvanised steel 25 x 25 x 2	800.16.026.4.32
I	Hex nut DIN 934-M6	800.03.005.3.30
J	Hex socket screw DIN 933-M6 x 40	800.01.319.3.30
K	Self-tapping screw ISO 7049-St4.8 x 13-C-H	800.01.493.3.30
L	Cylinder head screw for fixing track rail to substructure profile DIN 912-M8x25	800.01.018.3.30

DIN and standard parts by others or on request
CSN = Company standard no.

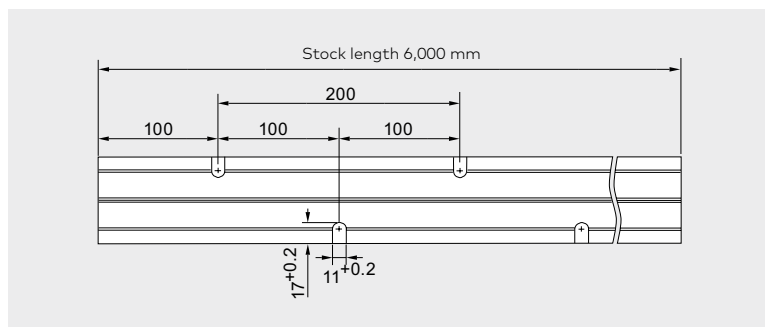
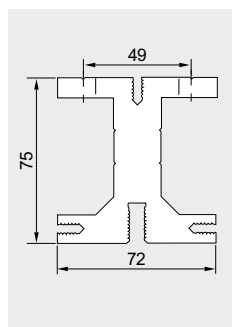
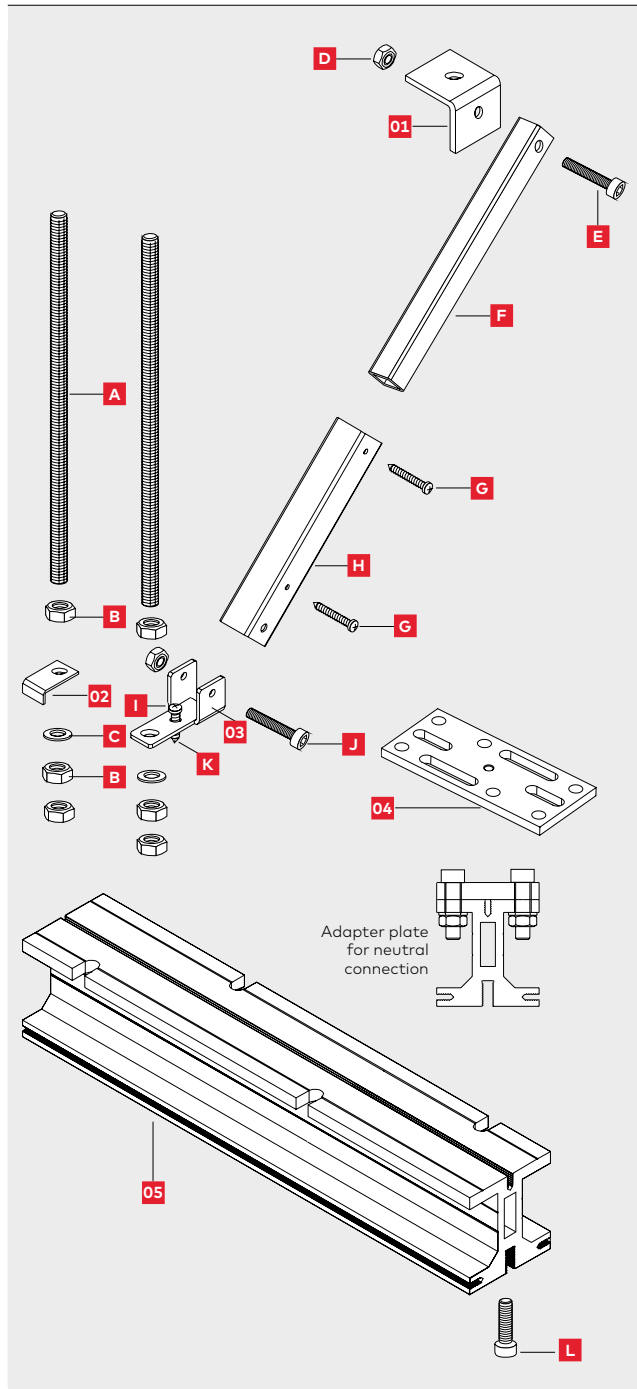

Space for your notes

Content

Panel Systems

34	General information
38	HSW EASY Safe
60	FSW EASY Safe
70	HSW-GP
74	HSW-R



Panel Systems

HSW EASY Safe

Security in use and elegance in design

Outstanding strengths of the HSW EASY Safe system:

- The optional safe use of laminated safety glass increases security and also widens the creative possibilities.
- A visible status display with a clear colour system indicates the status of the top locking device on the single-action sliding panel or double-action sliding panel. This gives a better overview and even more security.
- Double brush seals in the top and bottom door rails, successfully minimize drafts.



Intelligent solutions for more convenience and security

HSW EASY Safe – More clarity and easier locking thanks to status display

Locking status at a glance

Security and convenience in one: The top door locking device clearly shows the locking status of the door panel on the status display. This gives the user a greater feeling of reassurance and security.



Less draft for even greater comfort

Innovative double brush seals in the top and optional in the bottom door rails improve door closure and noticeably minimize the amount of draft. The vertical brush seals, which are also optionally available, can be fitted up to the full height of the panel and give additional draft proofing – for noticeably greater comfort.



Simple locking with hand or foot

Multilock – Three locking possibilities in one component

The new Multilock system opens up a new world of simplicity

The Multilock combines three locking possibilities in one compact element and can be installed effortlessly in the bottom door rail.



Easy foot-operated opening and closing

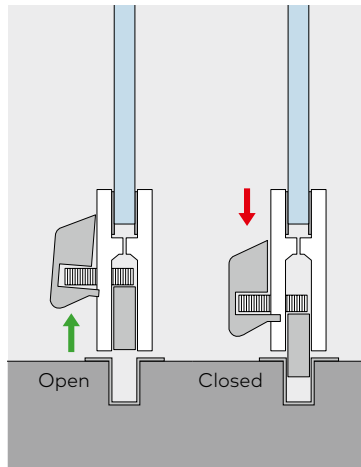

Simplicity with clear benefits:

The 3-in-1 Multilock can be offered in three options for secure locking: side locking device, front locking device or cylinder lock.

- Maximum convenience with foot-operated locking options for the face-mounted floor bolt – simple and hassle-free.

Innovative hold for more security

VSG – Improved security with the optional use of laminated safety glass



Creative freedom combined with security

Thanks to the innovative Clamp&Glue bonding technology, the HSW EASY Safe system allows the use of highly secure laminated safety glass. With the insertion of inlays within the laminated safety glass, the horizontal sliding wall can be used as a custom design element, thus setting new standards in interior design.

Hassle-free installation thanks to the new Clamp&Glue technology

The fixing process with HSW EASY Safe is incredibly simple. The special adhesive is fed through an injection hole in the two upper door rail halves to the adhesive channel where it spreads out evenly. After a drying time of just 15 minutes the panel can then be installed.

Attractive added value:

- Laminated safety glass makes the application of HSW EASY Safe not only attractive, but also more secure.
- The innovative Clamp&Glue technology enables easy bonding and also ensures that fittings and LSG (from TSG) are held firmly in place.
- Special inserts in the laminated safety glass offer huge design freedom as well as additional functions such as protection from the sun, noise reduction and privacy screening.

The inlay can be gradually pressed out using clamping force. The bonding of the glass with the fitting prevents the fitting from slipping out of the glass due to possible decrease in clamping force.

HSW – Transparent versatility

Horizontal sliding walls are used in a wide range of different project types, and for both internal and external applications. These partitions can be flexibly designed to suit the site of installation, structural conditions and design concept. They can satisfy a broad spectrum of requirements in relation to styling, material and finish

or colour, and can also be equipped with individually fabricated panels to perform special functions. Additional utilisation of the dormakaba substructure allows a simple, reliable and secure installation of the entire HSW system.

HSW – Horizontal Sliding Walls

Panels slide individually – stacking track required

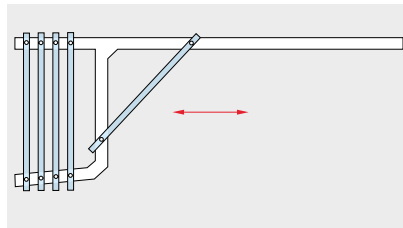

HSW EASY Safe

Glass assembly with top and bottom door rail

HSW-GP

Glass assembly with single-point fixings.

HSW Horizontal Sliding Walls, fully framed

Panels slide individually – stacking track required

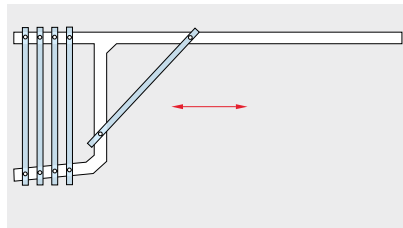

HSW-R

Fully framed for toughened safety glass, laminated safety glass or double glazing

Product overview

HSW EASY Safe

With the HSW Easy system, the panels create a continuous transparent face completely without side frame elements. Under certain circumstances, an additional wind deflector can, however, be provided at the glass edges as a preferred option.

FSW EASY Safe

The FSW EASY Safe folding sliding wall system offers both high transparency and enhanced user safety. Door rails top and bottom and roller carriers at the end of every second panel make it ideal for inline configurations. Visually compatibility with HSW EASY Safe panels means that both systems can be effectively combined in the access frontages of a building.

A defining characteristic of the HSW-GP is the single-point fixings that hold the glass in combination with the conventional track rail profile. The design with its high-quality stainless steel elements and glass-flush single-point fixings provides a perfect complement to contemporary architecture.

HSW-R

The HSW-R sliding glass panel frontage is suitable wherever likely to be exposed to high wind loads – for example, for shop windows and store entrances located in the façade/on the outside of the building. Aluminium alloy frames clamp the glass on all sides, with lateral rubber lip seals and double brush seals top and bottom providing added weather protection.

HSW-GP

Use and features	HSW EASY Safe	FSW EASY Safe	HSW-GP	HSW-R
Shop fronts	●	●	○	●
Shop fronts with climate barrier function				○
Internal room divider	●	●	●	○
Glass thicknesses (mm) Toughened safety glass (TSG)	10/12/13/ 15/17/19	10/12/13/ 15/17/19	10/12	
Glass thicknesses (mm) Laminated safety glass (comprising TSG sheets)	10.8/12.8/13.5/ 15/17/19	10.8/12.8/13.5/ 15/17/19	10.8 / 12.8 / 13.5	8–24 ¹⁾
Assembly height (max. mm)	4,000	3,000	3,000	3,000
Panel width (max. mm)	1,250	1,100	1,200	1,100
Panel weight (max. kg)	150	80	100	100
Access panels (pivoting type)				
– Pivoting end panel, single-action	●	●	●	●
– Pivoting end panel, double-action	●	●	●	●
– Offset hung end panel	●	●		●
– Single-action sliding panel	●	●		●
– Double-action sliding panel	●	●		●
– Invisibly integrated door closer ITS 96	●			●

● Standard ○ Optional * Weight dependent on panel fittings ¹⁾ also usable for double glazing units.

For more information please see the technical brochure
HSW FLEX Therm, 05453451532

Panel design

With the features that the different panel types have in common **HSW EASY Safe** satisfies all the requirements placed on transparent façades in the typical applications that arise.

- All panel types are provided with a bottom and a top door rail, which hold the glass safely.
- HSW assembly only with sliding panels, pivoting end panels and fixed panels can do without an additional carrier profile. For single- and double-action sliding panels the carrier profile is indispensable. When an assembly incorporates single- or double-action sliding panels then the carrier profile is provided for all panel types.
- The glass panes can have the following glass thicknesses: 10 mm, 10.8 mm, 12 mm, 12.8 mm, 13.5 mm, 15 mm, 17 mm and 19 mm. (tolerance range +/- 0.5 mm)
- When using laminated safety glass the Clamp&Glue technology provides secure hold without the need for glass drilling.
- The top panel profile (either door rail or carrier profile) incorporates a double brush seal as standard. As an option the bottom door rails can have double brush seals as well.
- Excellent draft protection is reached when additional sealing profiles with matching double brushes are used at the vertical glass edges as well.

HSW EASY Safe is certified to have reached the following tests:

- Wind load (Frame bending): EN 12210 Class 1
- Endurance strength: DIN EN 1527 Class 3 and DIN EN 1191 Class 3
- Side impact: DIN EN 13049 Class 5 (highest class)
- Corrosion: DIN EN 1670 Class 4
- EPD (Environmental Product Declaration): ISO 14040

Sliding panel
without carrier profile

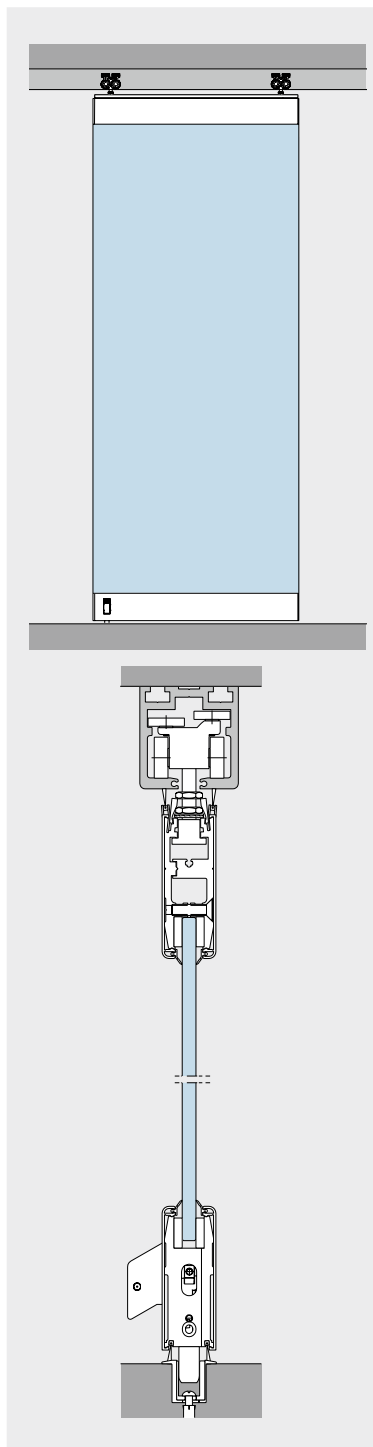

Sliding panel
with carrier profile

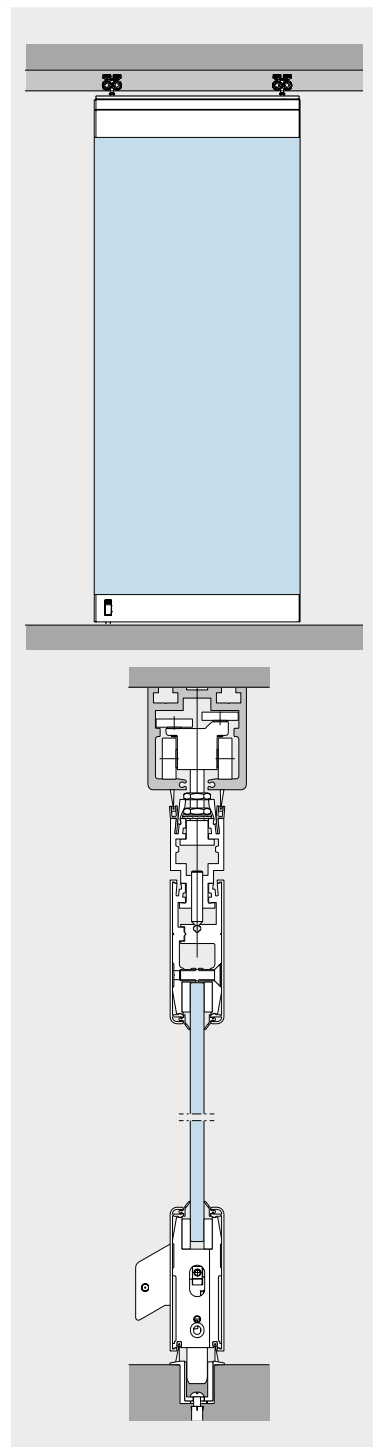

HSW-GP

Frameless all-glass system
with single-point fixings

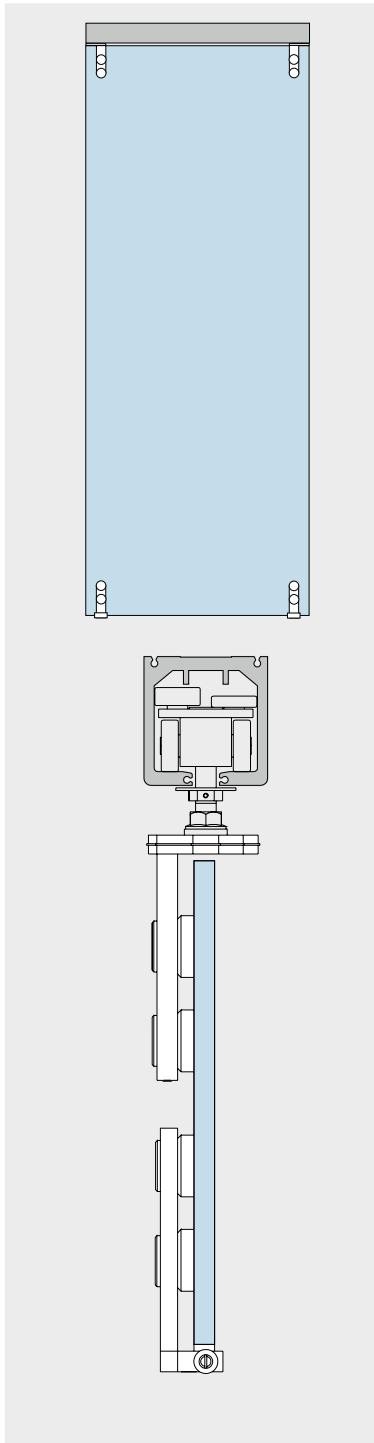
**HSW-R**

All-round frame

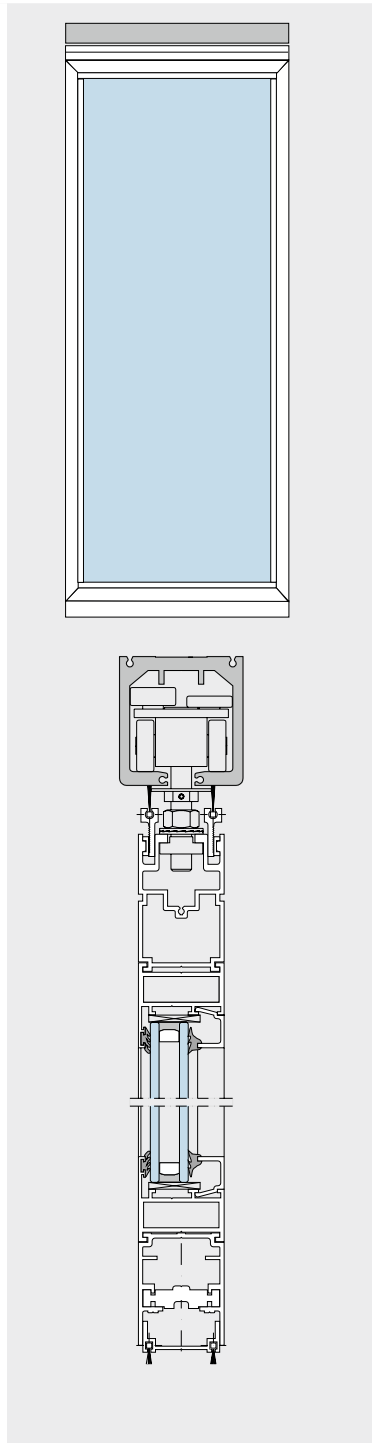

In the all-glass version HSW-GP, the panels without frame form a continuous, transparent face, with the use of single-point fixings creating a fine, elegant appearance.

The all-round frames of the individual panels of an HSW-R system offer not only high stability but also effective protection against external influences, with the option of either laminated safety glass (LSG), toughened safety glass (TSG) or double glazing units for the glazing.

Panel functions

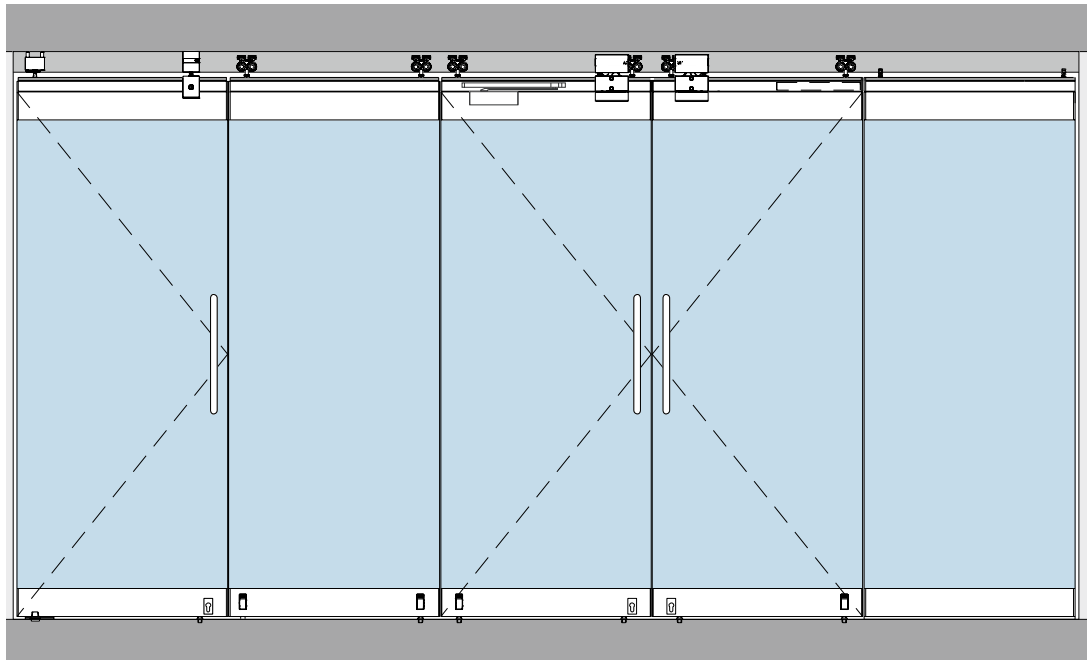

A presentation of the offset hung end panel and the sliding folding panel is available on pages 57 and 58

	Pivoting end panel, single- or double-action Non-sliding. Single-action panel with floor pivot and TS 92/TS 73 door closer. Double-action panel with floor pivot or BTS floor spring.	Sliding panel Basic movable panel without additional function.	Single-action sliding panel* Single-action sliding panel with TS 92 cam-action door closer, operational when frontage closed. (Alternatively with ITS 96.)	Double-action sliding panel* With ITS 96 door closer, operational when frontage closed.	Fixed panel Fixed panel design matching the design of the sliding panels in the assembly.
Max. panel height	4,000 mm	4,000 mm	3,600 mm	3,600 mm	4,000 mm
Max. panel width	1,250 mm	1,250 mm	1,250 mm (1,100 mm)	1,100 mm	1,250 mm
Max. panel weight	150 kg	150 kg	120 kg**	120 kg**	150 kg

The individual panels can also be of differing widths. The largest width should not exceed max. 115% of the smallest width.

*For these panel types please consider our notes on portal systems on page 107.

****Note:** The maximum permissible weight relates to the complete door assembly, including handles.

Door rails and general details

Bottom locking devices

All depicted combinations are also available as mirror arrangements.

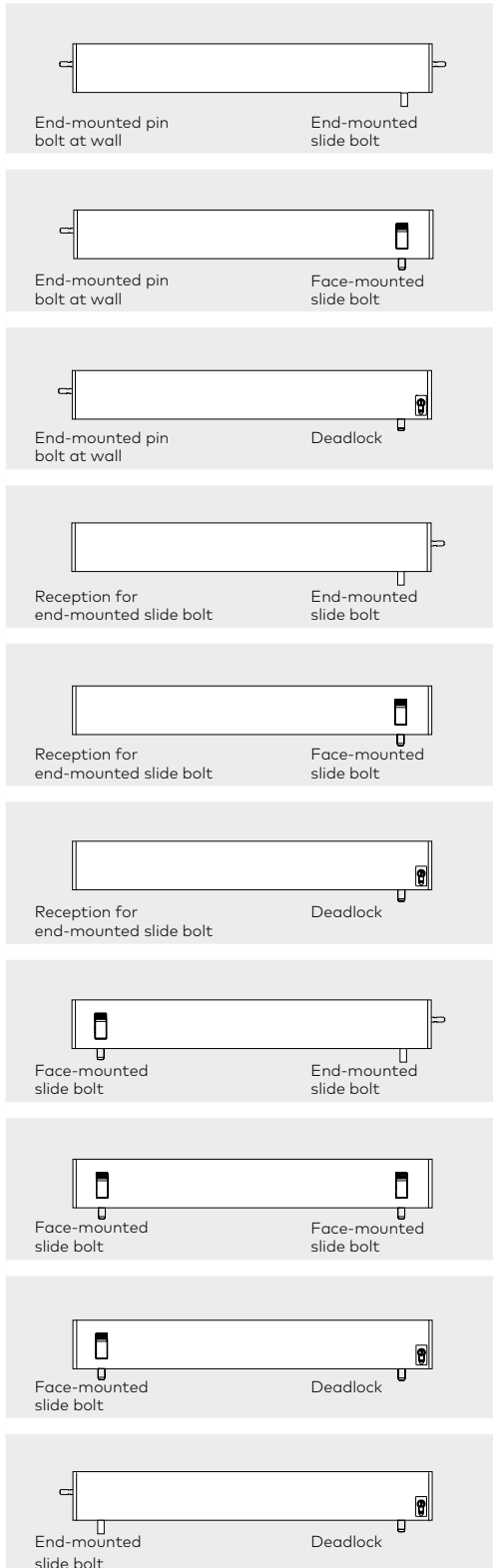

General parts and measurements

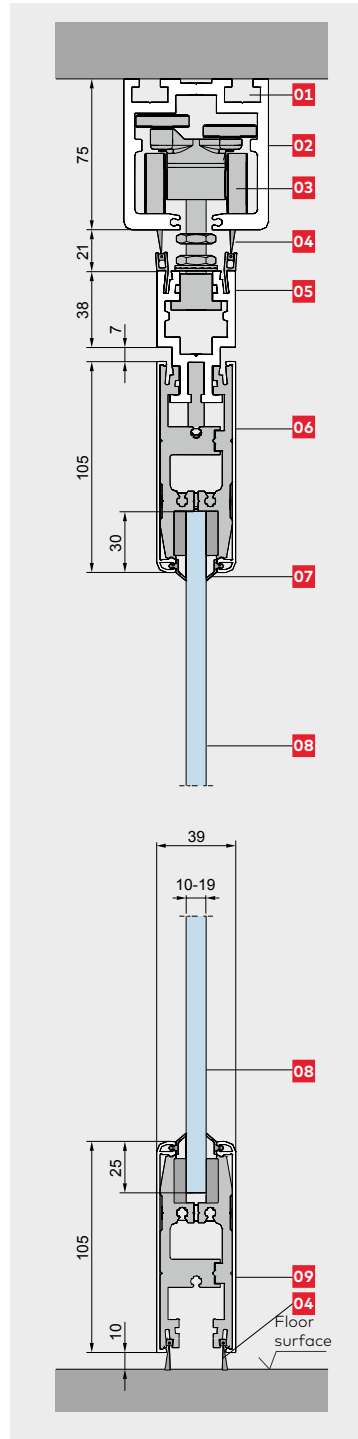

Irrespective of the function of the individual panels, an HSW EASY Safe system comprises the following basic components:

- 01** Two parallel channels suitable for M 10 screws and clamp connectors
- 02** Track rail
- 03** Roller carrier
- 04** Double brush seals on top (bottom layout is optional)
- 05** Carrier profile
- 06** Top door rail and (consisting of basic profiles, cover profile and lateral end caps)
- 07** Rubber seal, bridges the gap between cover profile and glass panel
- 08** Toughened safety glass or toughened laminated safety glass 10–19 mm (by others)
- 09** Bottom door rail, both comprising base profiles with cover profiles and end caps

Pivoting end panel

single- or double-action

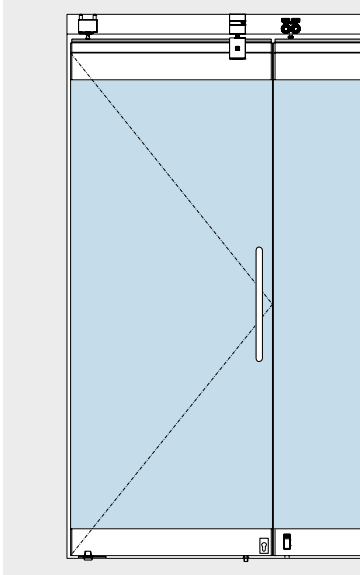

Pivoting end panel, single- or double-action, with floor pivot
 Non-moving and always equipped with a locking dead-lock and the option for an additional upper locking unit.

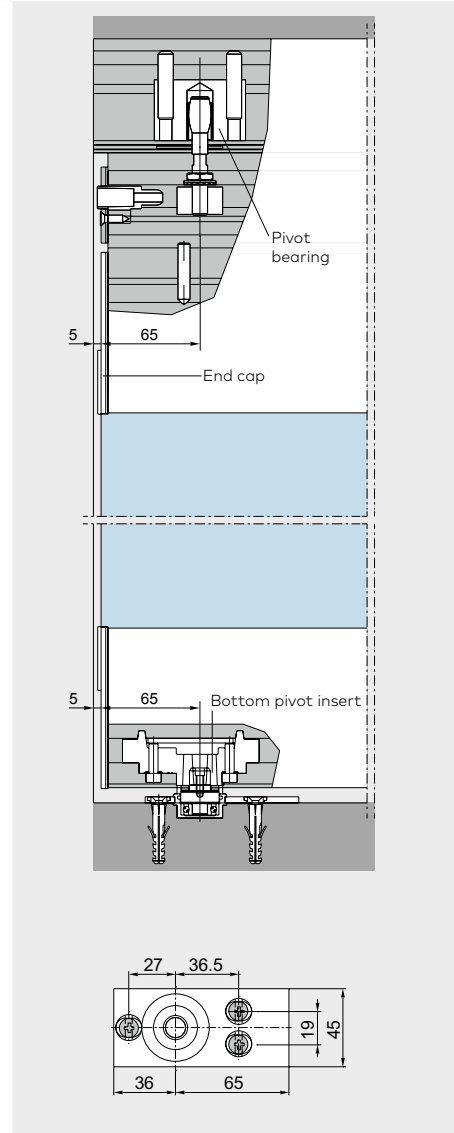
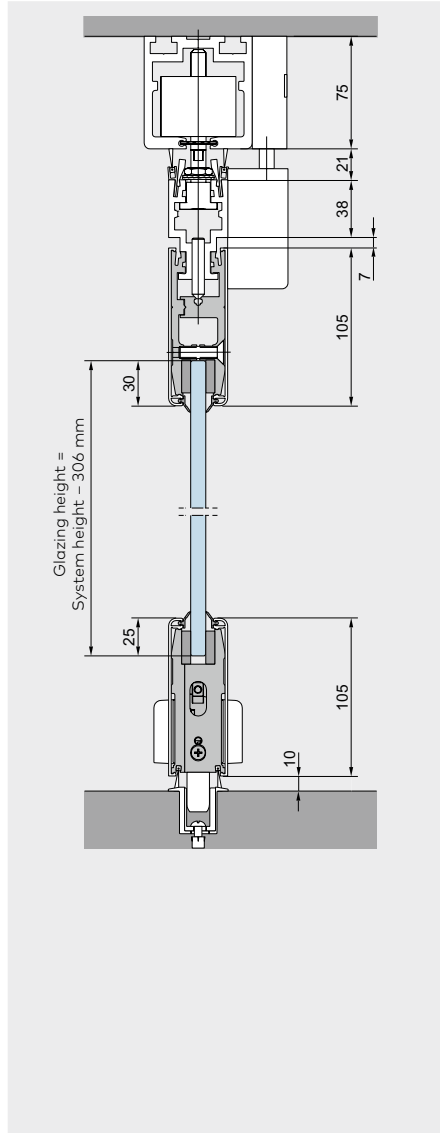

Pivoting end panel, single-action

with stop-type end caps top and bottom.

Pivot point variants:

- Floor pivot with round spindle, optional combined with DORMA TS 92 overhead door closer*
- BTS 84 for panels up to 100 kg, with optional hold-open at 90° door opening angle
- BTS 80 for panels up to 150 kg with adjustable hold-open device

Pivoting end panel, double-action

Pivot point variants:

- Floor pivot with round spindle
- BTS 84 for panels up to 100 kg, with optional hold-open at 90° door opening angle
- BTS 80 for panels up to 150 kg with adjustable hold-open device

Pivoting end panel, single- or double-action, with floor spring

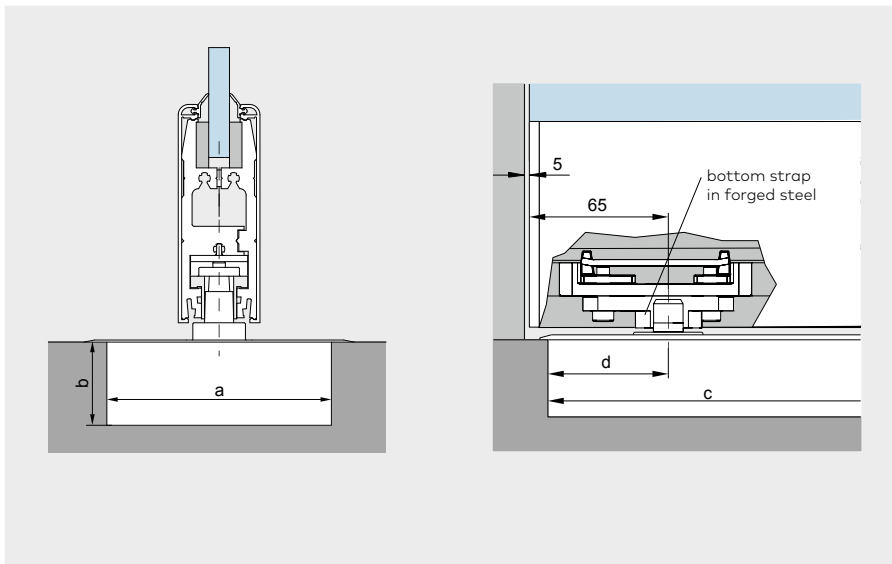

Mounting dimensions (in mm)

	BTS 84	BTS 80
a	108	78
b	40	60
c	306	341
d	51–58	51–57

* Data and features TS 92 see page 51.

Pivoting end panel

single- or double-action, with additional upper locking bolt

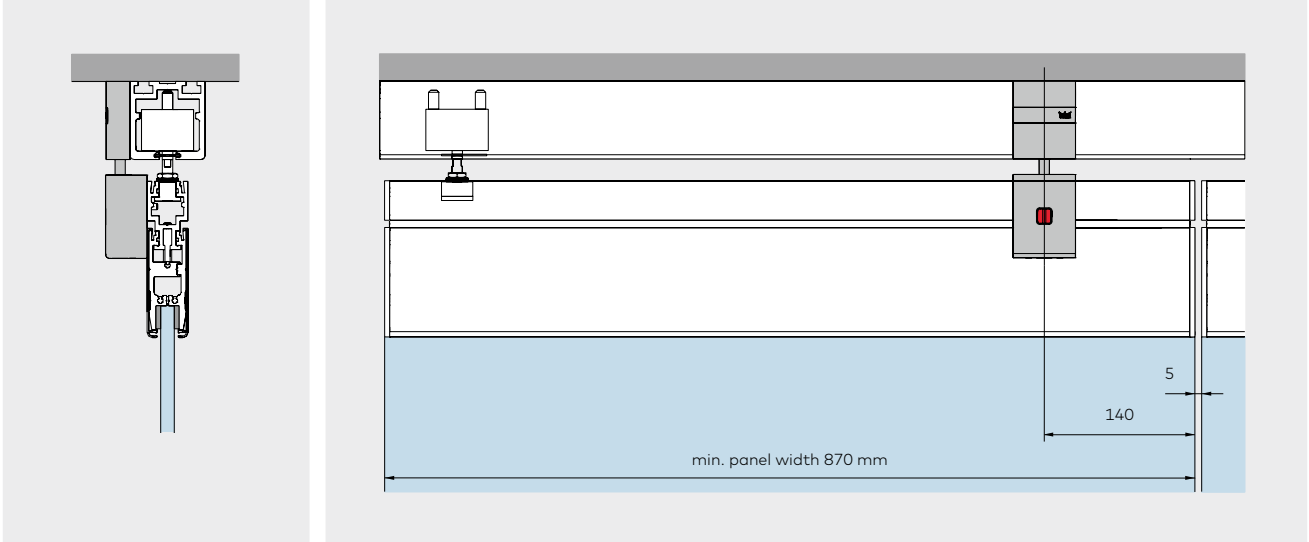

Additional upper locking bolt

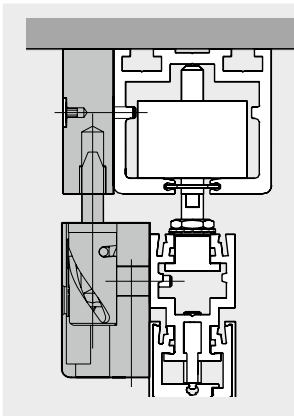

New drill hole of pattern

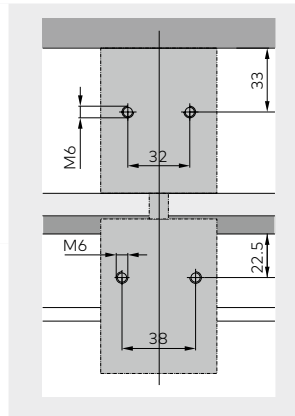

End cap with stop (optional)

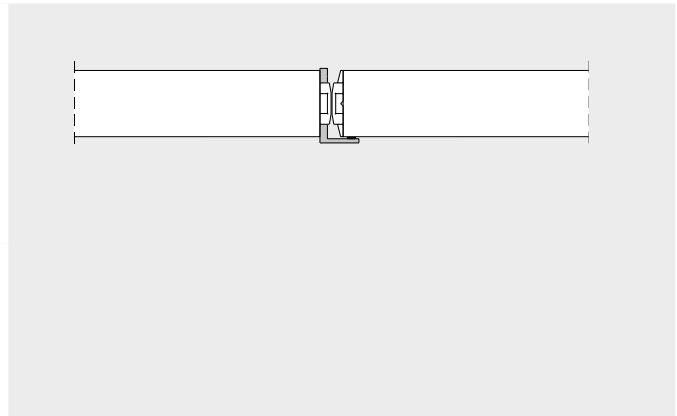

Data and features		BTS 80			BTS 84		
		3	4	6	2	3	4
Spring strength (EN)							
Standard and external doors	≤850 mm				●		
	≤950 mm	●				●	
	≤1,100 mm		●				●
	≤1,400 mm			●			
Closing speed adjustable by valve	130°-0°				●	●	●
	130°-20°				●	●	●
	175°-0°	●	●	●			
Delayed action (adjustable by valve) (selectable alternative to the hold-open feature)		●	●	●			
Max leaf weight (kg)		300	300	300	100	100	100
Hold open	90°				●	●	●
	adjustable	●	●	●			
Dimension	Length	341	341	341	306	306	306
	Overall width	78	78	78	108	108	108
	Height	60	60	60	40	40	40
Door closer tested to EN 1154		●	●	●	●	●	●

Sliding panel

Basic movable panel without additional function.

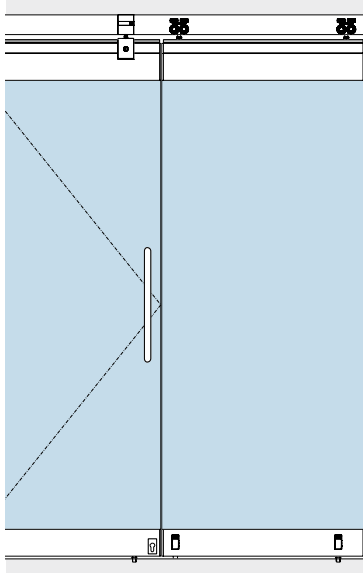

The sliding panels are movable. Once in their closed position, they are locked. The locking components provided in the bottom door rail can be face-mounted slide bolts, end-mounted slide bolts, end pin bolts or deadlocks.

The structure of the bottom door rail applies also to single-action/double-action sliding panel.

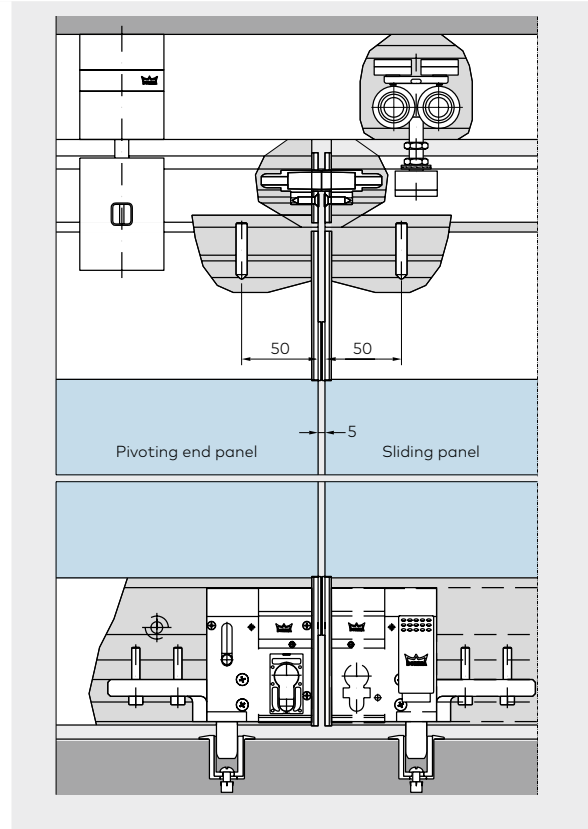
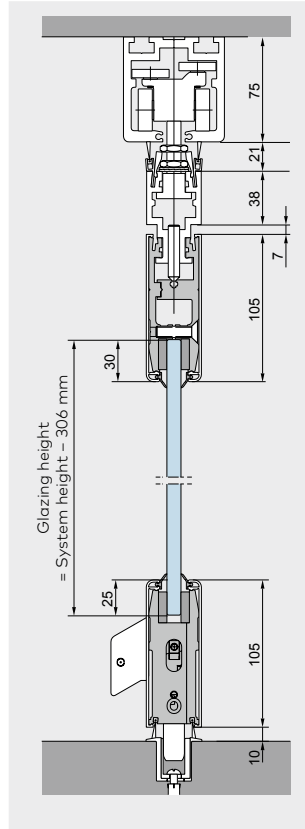

Bottom door rail with face-mounted slide bolt

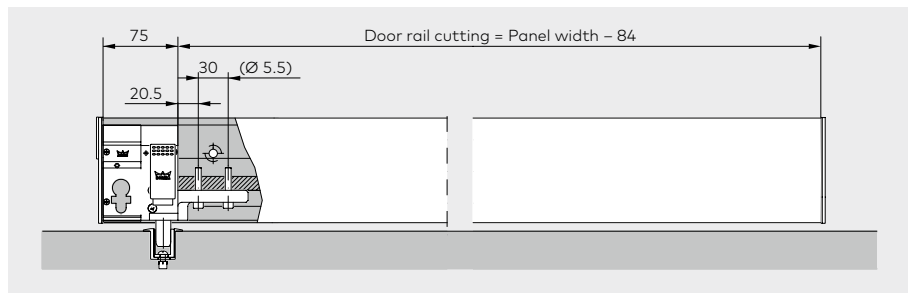

Machining of cover profile (face-mounted slide bolt)

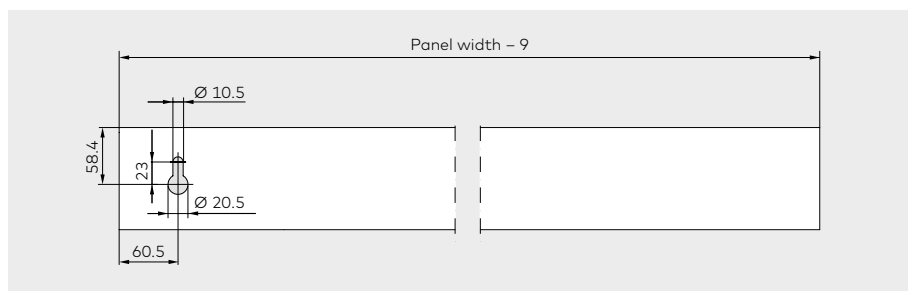

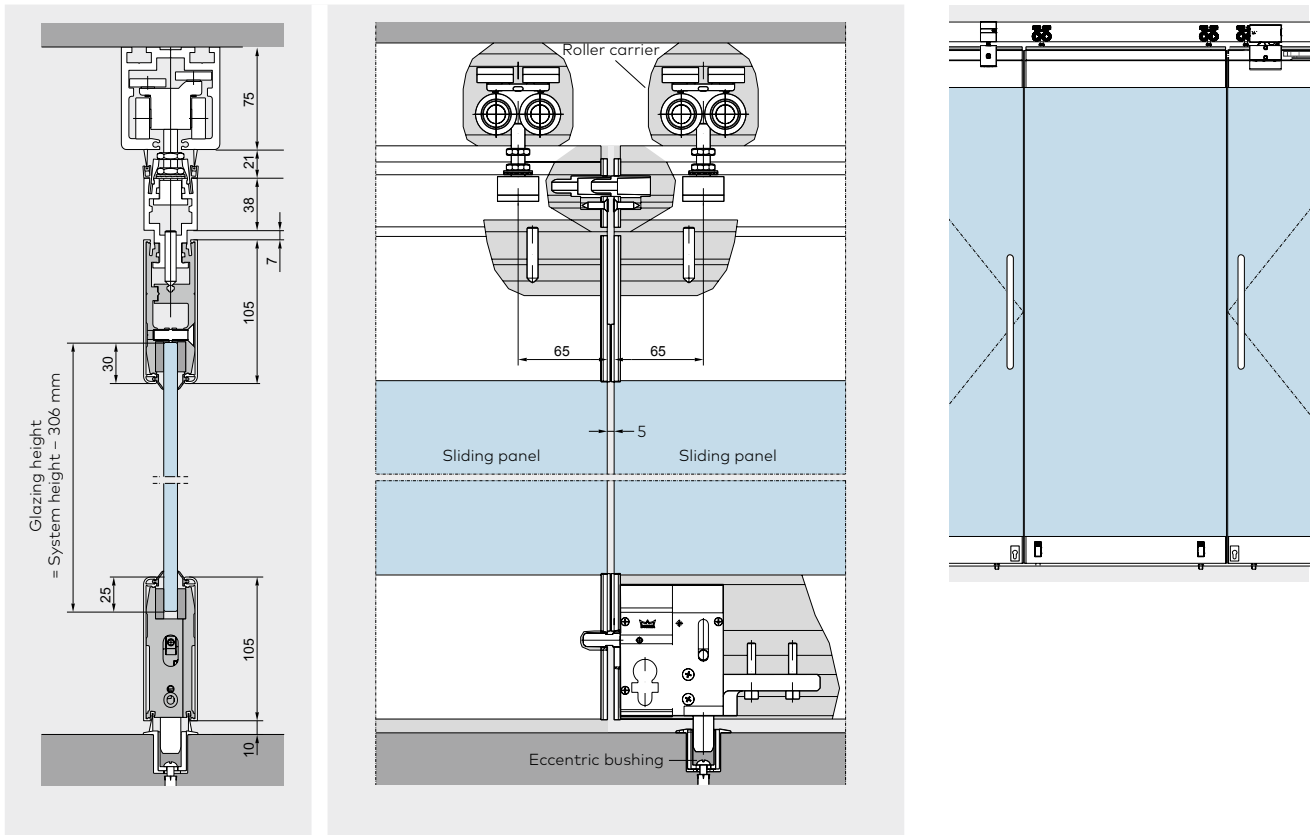

Bottom door rail with face-mounted slide bolt on both sides

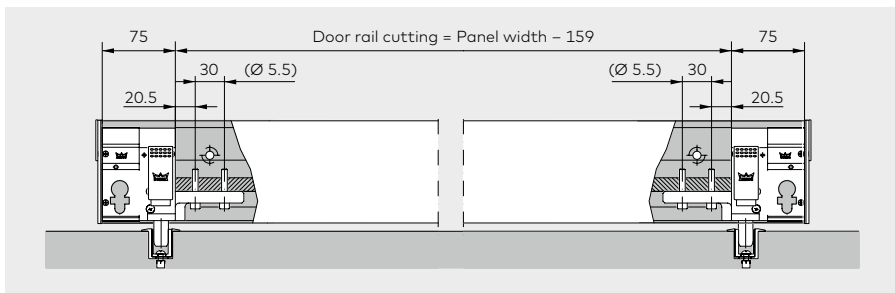

Machining of cover profile (face-mounted slide bolt)

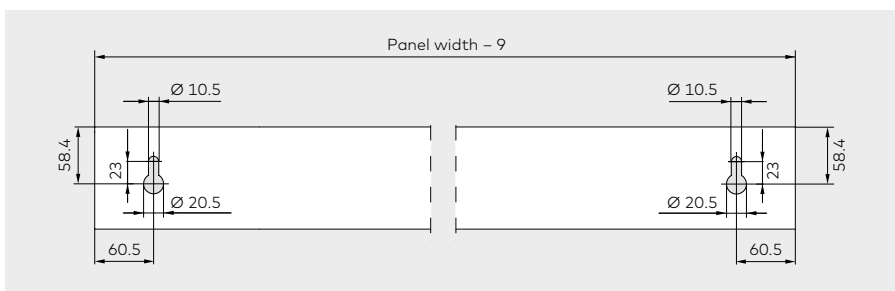

Single-action sliding panel

with DORMA TS 92 cam-action door closer

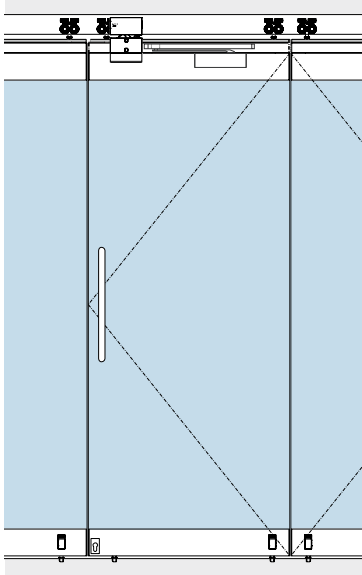

This panel type is installed where doors only need to be opened in one direction, either inward or outward. In both cases, the cam-action door closer is fixed to the internal side of the assembly. If you are considering this panel type, please note our advisories relating to portal systems on page 107.

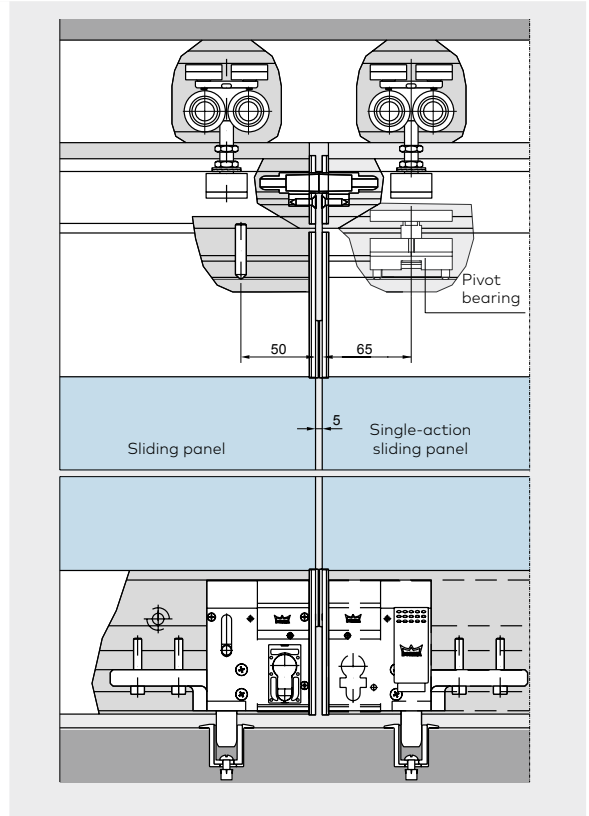
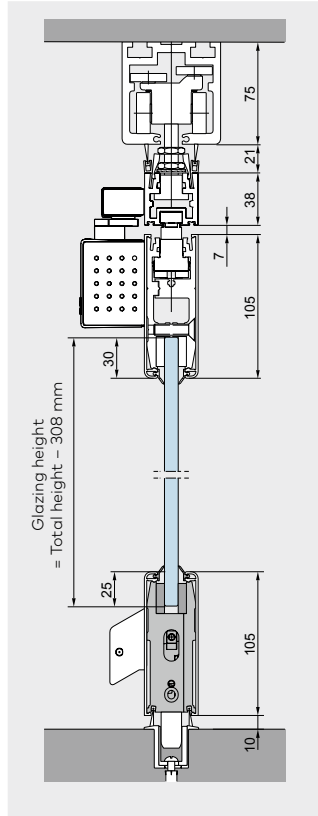



Status display

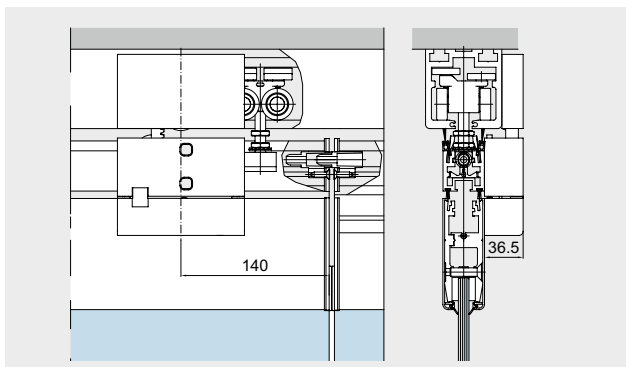

Sliding function	locked	locked	open
Door function	open	locked	locked

Data and features: TS 92

Closing strength/size	EN 2-4
Closing speed and latching action independently adjustable at two separate valves	180°-15° 15°-0°
Non-handed	yes
Cushioned stay limit adjustment	80°-120°
Hold-open adjustment	75°-150°
Weight	1.9 kg
Length	281 mm
Overall depth	47 mm
Height	65 mm

Standard assembly

top: Pivot bearing, TS 92 with slide channel, one locking device.
bottom: Face-mounted slide bolt as pivot (released for sliding function), deadlock.

Optional equipment

top: Additional locking device (upper locking unit) to secure the panel in the area of a reshuffle bypass or for more stability in closed position (Illustration see page 40).
bottom: Second face mounted slide bolt instead of deadlock.

Single-action sliding panel

with integrated door closer ITS 96, 2-4

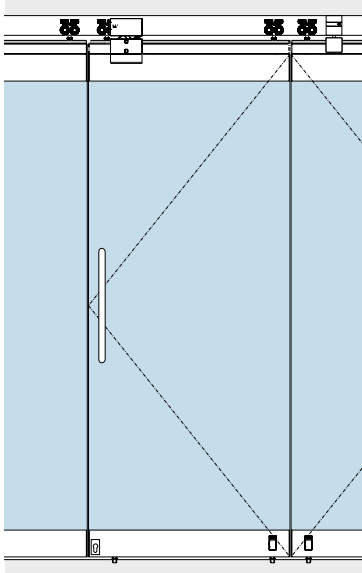

This panel variant is used where the door element is required to only open in one direction, either inward or outward. If you are considering this panel type, please note our advisories relating to portal systems on page 107.

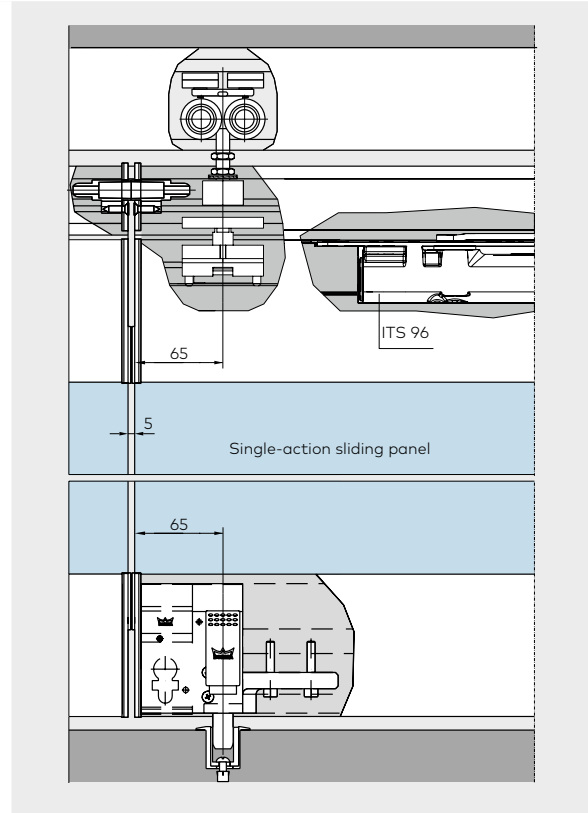
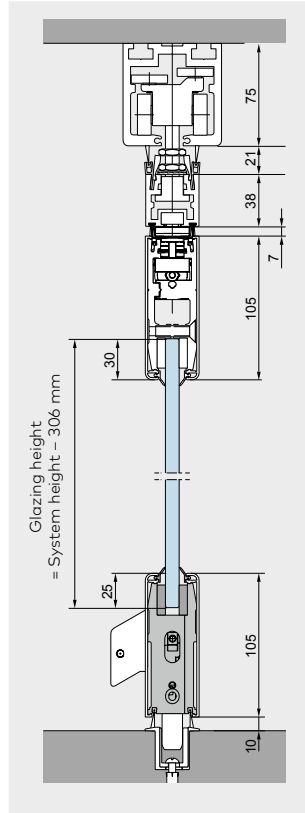

Standard assembly

- top: Pivot bearing, ITS 96 with slide channel, one locking device.
- bottom: Face-mounted slide bolt as pivot (released for sliding function), deadlock.

Optional equipment

- top: Additional locking device (upper locking bolt) to secure the panel in the area of a reshuffle bypass or for more stability in closed position.
- bottom: Second face mounted slide bolt instead of deadlock.

Data and features: ITS 96, Gr. 2-4	
Closing strength/size	EN 2-4
Max. panel width	≤1,100 mm
Max. panel weight	≤120 kg
Closing strength continuously variable	Adjusting screw
Closing speed continuously variable	by valve
latching speed is adjustable from 15°-0°	by valve
Cushioned stay limit mechanically variable	yes
Max. opening angle	ca. 120°
Hold-open variable	yes (door stop necessary)
Weight	1.3 kg
Length	277 mm
Overall depth	32 mm
Height	42 mm
Door closer tested according to EN 1154	yes

Double-action sliding panel

with integrated DORMA door closer ITS 96, 2-4.

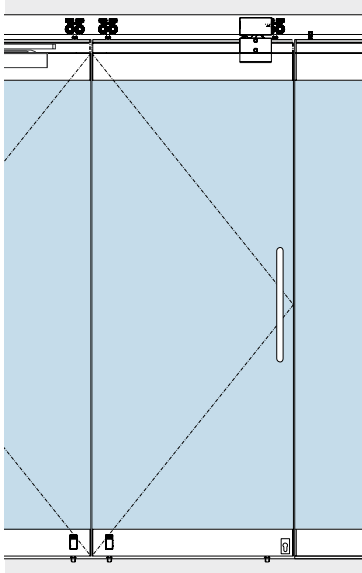

Being virtually invisible, its presence has no effect on the overall appearance of the partition. In its standard form, ITS 96 is provided with a 90° hold-open. If you are considering this panel type, please note our advisories relating to portal systems on page 107.

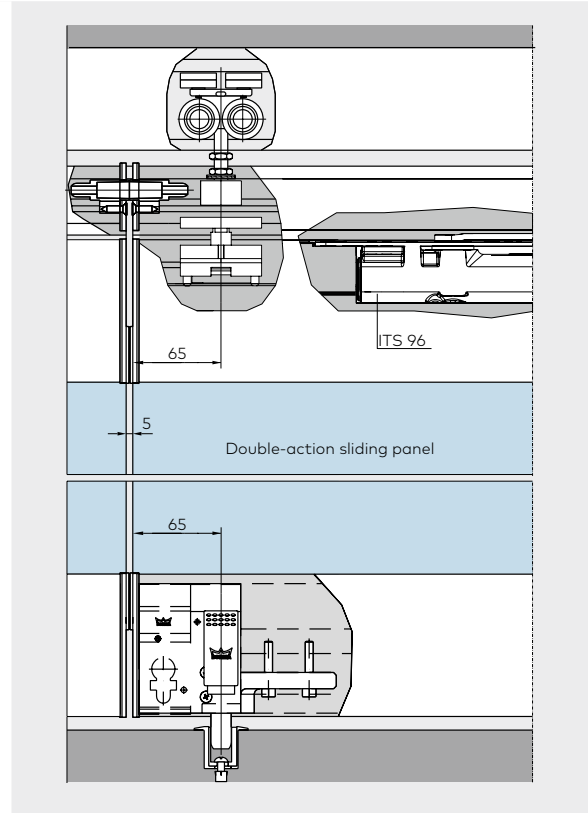
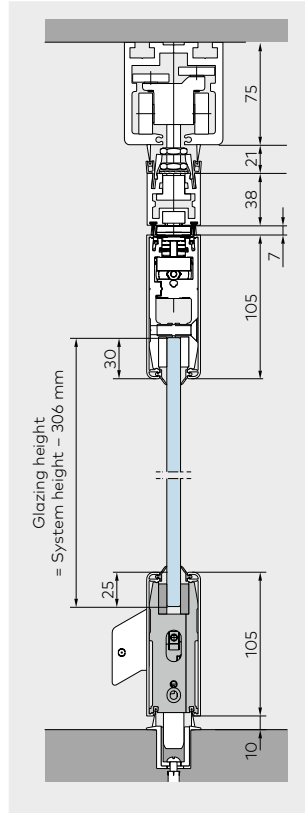

Hole of pattern upper locking unit

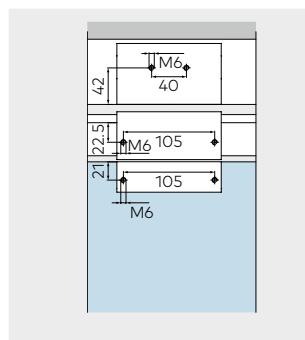

Upper locking unit

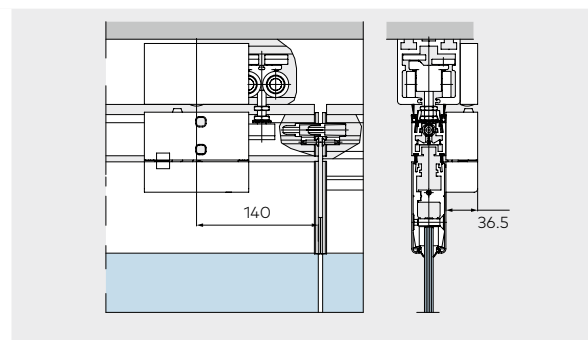

Standard assembly

- top: Pivot bearing, ITS 96 with slide channel, one locking device
- bottom: Face-mounted slide bolt as pivot (released for sliding function), deadlock

Optional equipment

- top: Additional locking device (upper locking unit) to secure the panel in the area of a reshuffle bypass or for more stability in closed position.
- bottom: Second face mounted slide bolt instead of deadlock

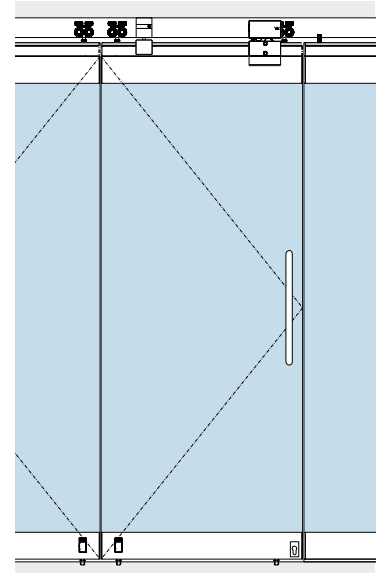
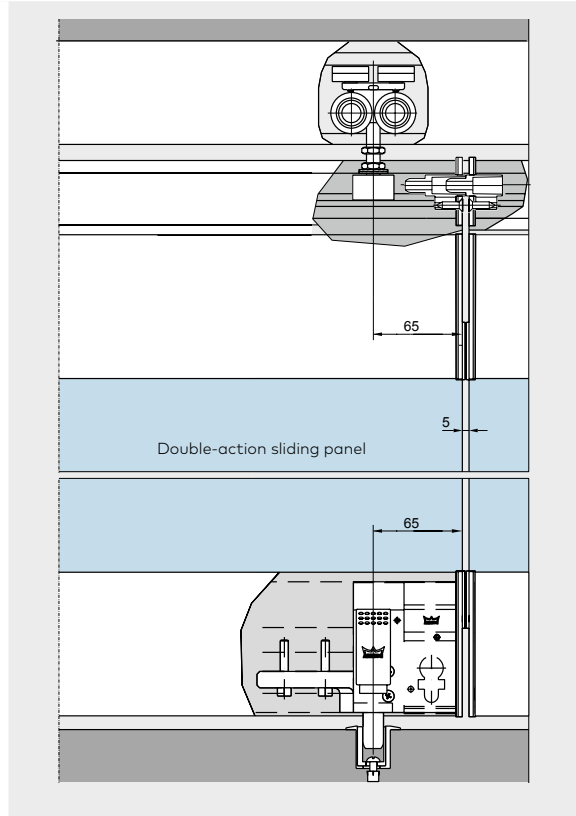
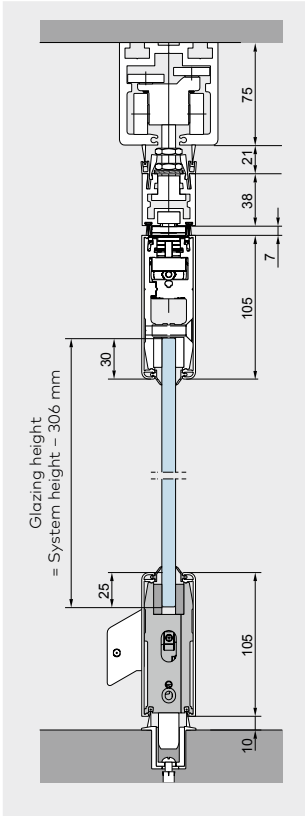

Additional upper lock

The additional upper locking bolt is used for single-action or double-action sliding panels as an optional addition to the upper locking unit at the other end of the door. In some cases it is recommended for additional stabilization of the carrier profile.

Hole of pattern additional upper lock

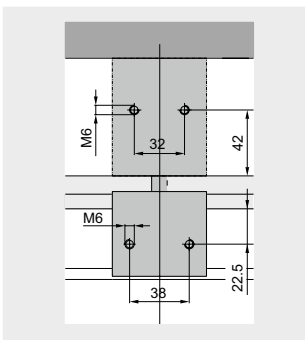

Additional upper lock

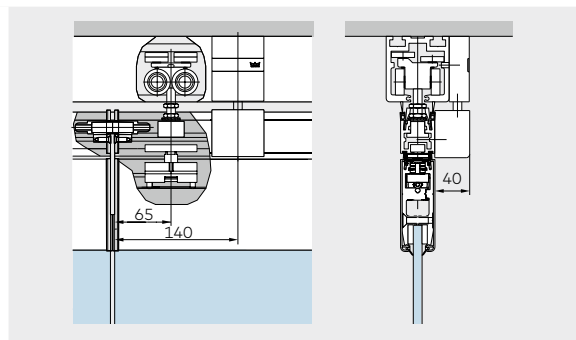

Fixed panel

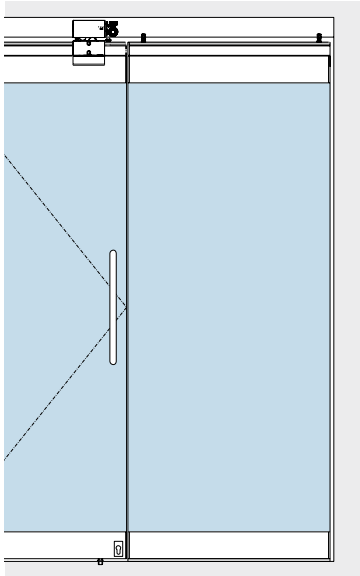

Non-moving side panel, independent of the rest of the system. The fixed side panels are of the same basic design as the sliding panels and continue the appearance of the movable part of the frontage without any optical break. If required, the retaining devices at the top can be replaced by a carrier system to convert such a panel into a sliding panel.

Standard assembly

- top: Retaining devices fixed to the track rail.
- bottom: Spacer profile fixed to the floor; access for fixed end pin of the adjacent panel.

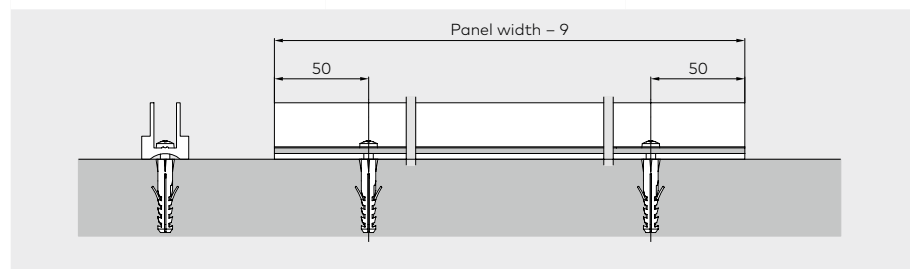
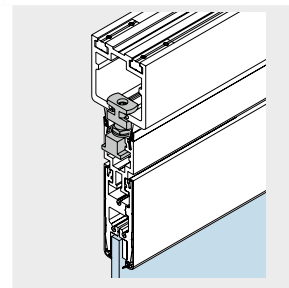
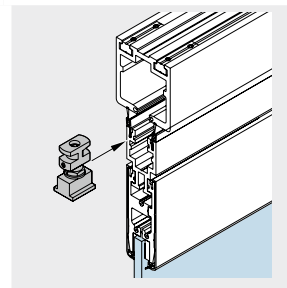
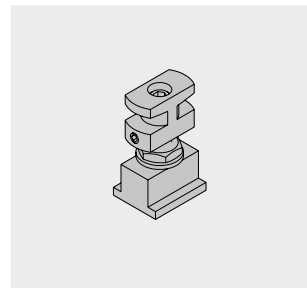
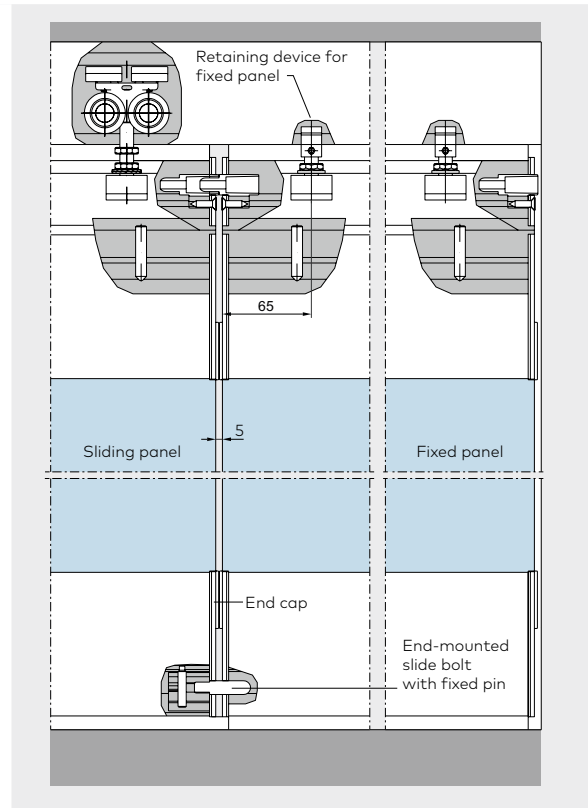
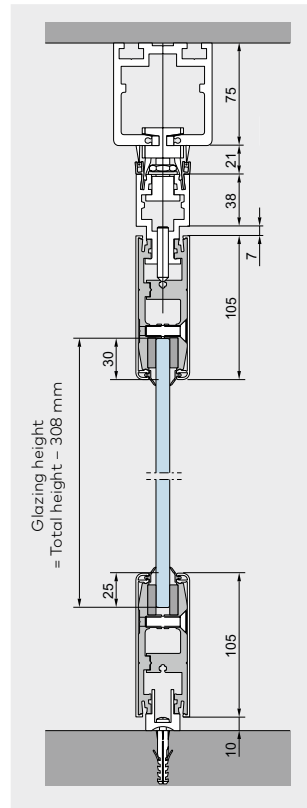

Offset hung end panel

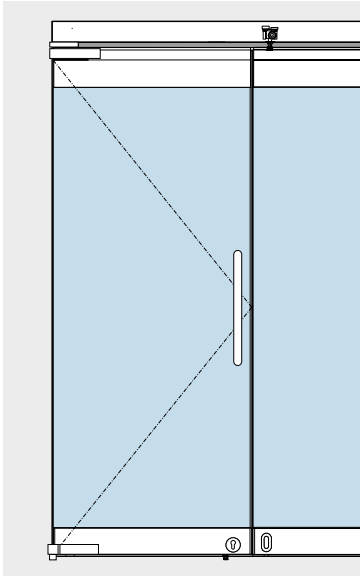

Offset hung end panel

Single action panel, non-sliding, operates independently of the rest of the system. The single action door with offset pivoting arm assembly can be swung around 180°, so leaving the entire operating zone free. A bottom deadlock secures the closed leaf.

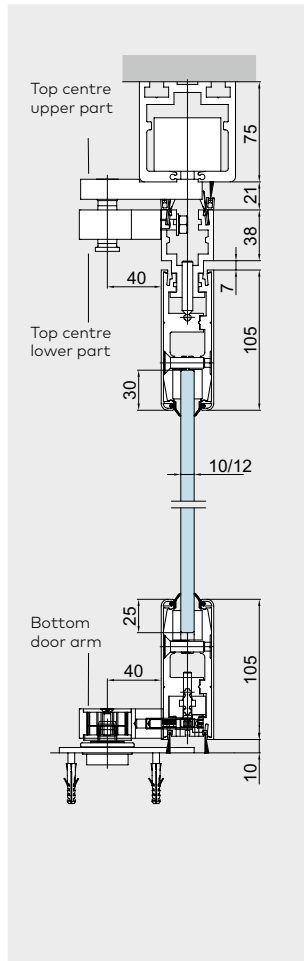

Position 90° and 180° opening angle at wall
 position 180° opening angle at fixed panel

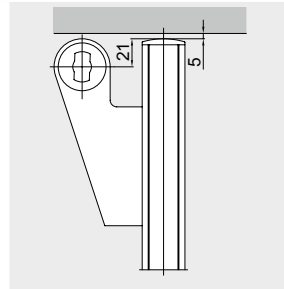

180° opening angle
 Offset hung end panel at fixed panel

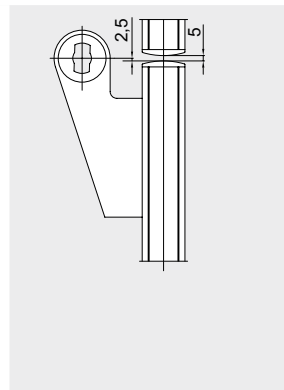

Max. panel weight 100 kg

Pivoting end panel views as seen from below

Sliding / folding panel

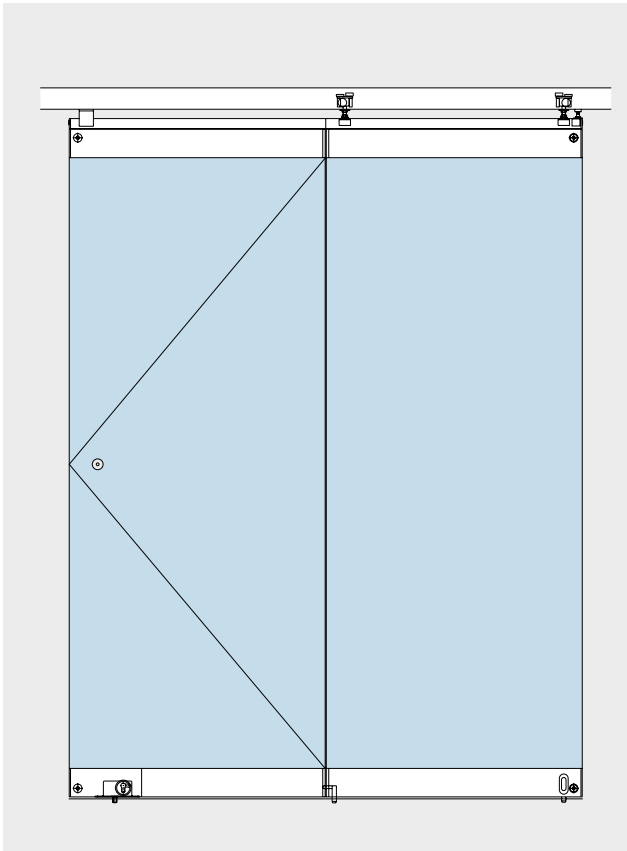

Hinged, with lock and slide bolt at the bottom, latching bolts top and bottom for fixing the final folding panel to the slide panel.

Max. panel sizes and weights

- Max. panel width 2 x 1,000 mm
- Max. system height 3,000 mm
- Max. panel weight 2 x 70 kg

Magnetic door holders top and bottom

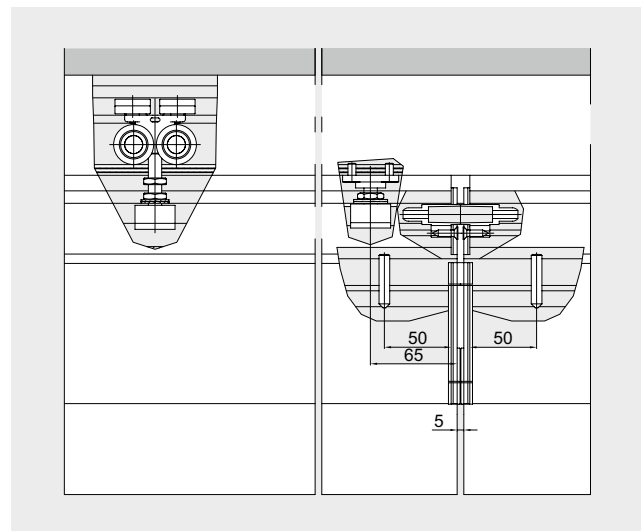
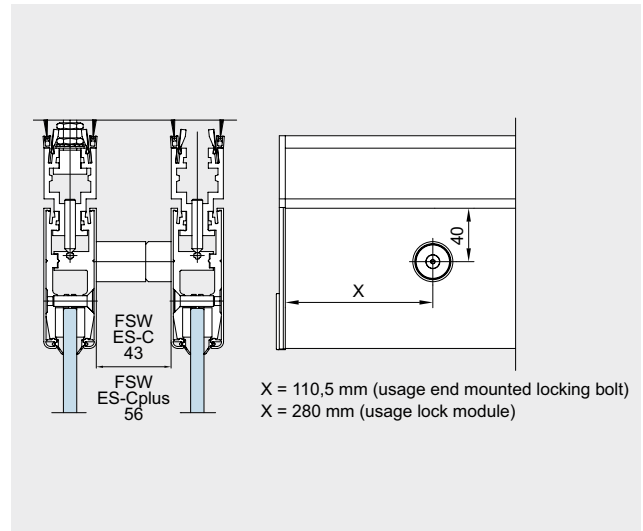

End mounted slide bolt

Panel hinge

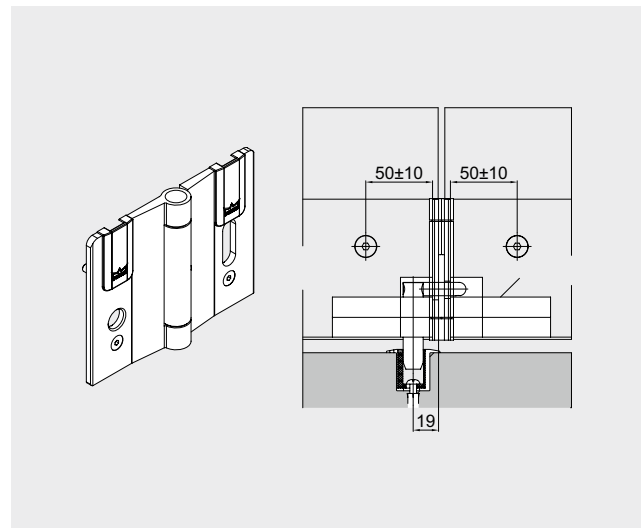
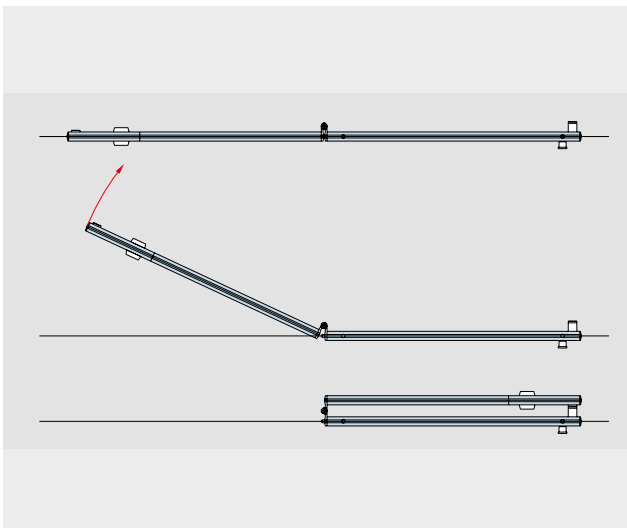

Space for your notes

Types and functions

FSW toughened glass folding walls featuring door rails top and bottom and a roller carrier at the end of each second panel.

FSW folding sliding walls are suitable for linear configurations. With an FSW EASY Safe assembly, you can have either two or four panels (a basic panel and 1 or 3 folding panels) linked together. Where two counter-running (bi-parting) assemblies are installed, it is possible to create frontages with up to eight FSW panels.

As the panels are visually compatible with the HSW EASY Safe pivoting/sliding panels, and both systems use the same track design, shop/store frontages or similar transparent partition systems can be made up of these two different types, with the FSW assembly at the free end or supplemented by a single- or double-action HSW end panel (types 4+5). FSW systems can be designed for either opening direction.

Example: Design with 2 x 2 panels (type 1c), bi-parting

- 01**
Track rail
- 02**
Upper locking bolt
- 03**
Roller carrier
- 04**
Face mounted slide bolt
- 05**
Upper pivot bearing of the basic panel
- 06**
Basic panel
- 07**
Folding panel

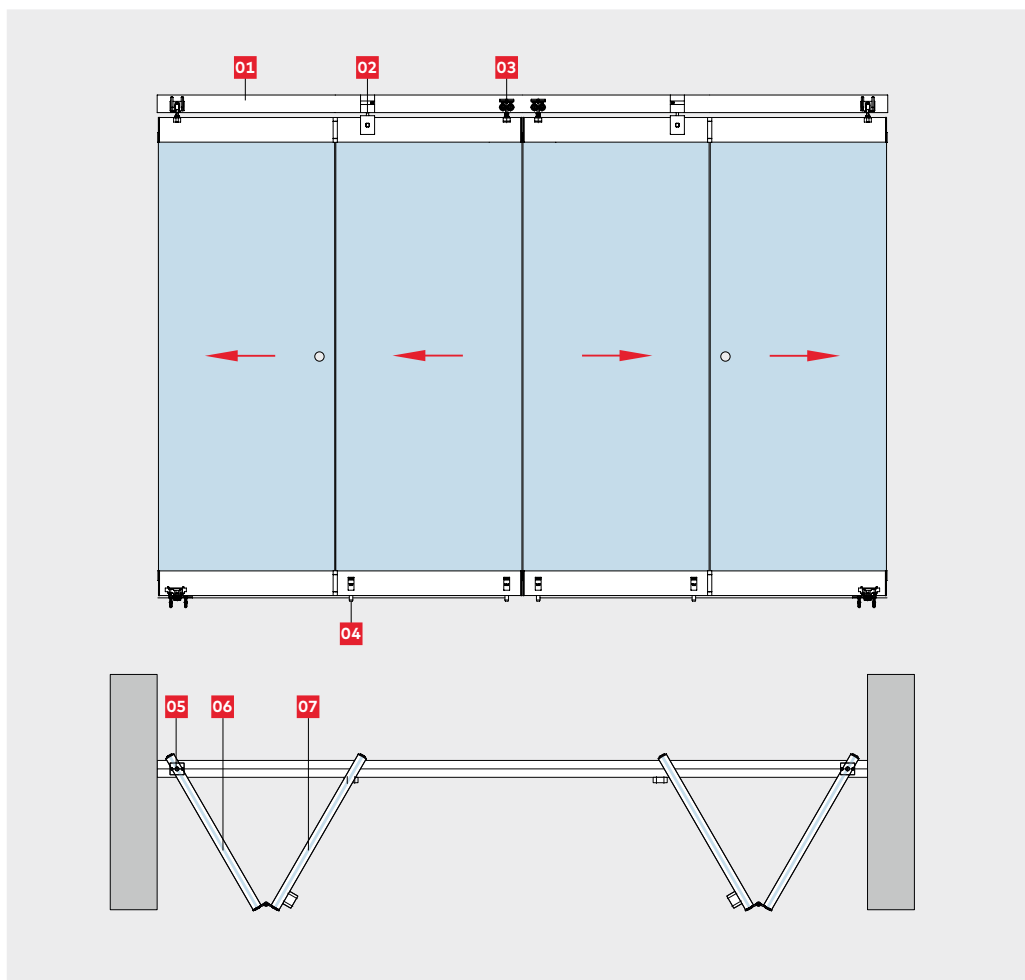

Max. panel sizes and weights	Basic panel with top pivot and floor pivot	Folding panel with roller carrier and lock bolts top and bottom	Folding panel with roller carrier and lock bolts top and bottom	Basic panel with roller carrier and lock bolts top and bottom
Max. assembly height	3000 mm	3000 mm	3000 mm	3000 mm
Max. panel width	1100 mm	1100 mm	1100 mm	1100 mm
Max. panel weight	80 kg	80 kg	80 kg	80 kg

The standard thicknesses are 10/12 mm toughened safety glass (TSG). Other thicknesses and glazing with laminated safety glass (LSG) available on request.

System components

Basic panel

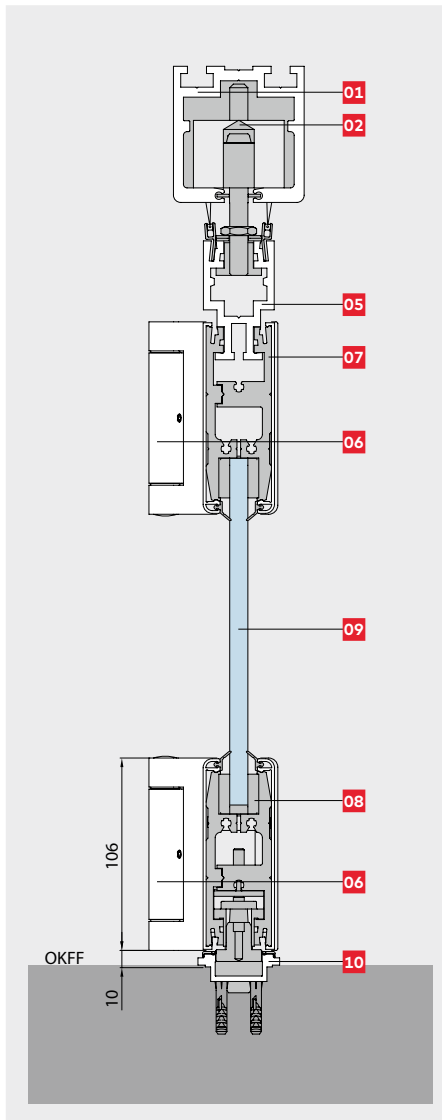

Folding panel

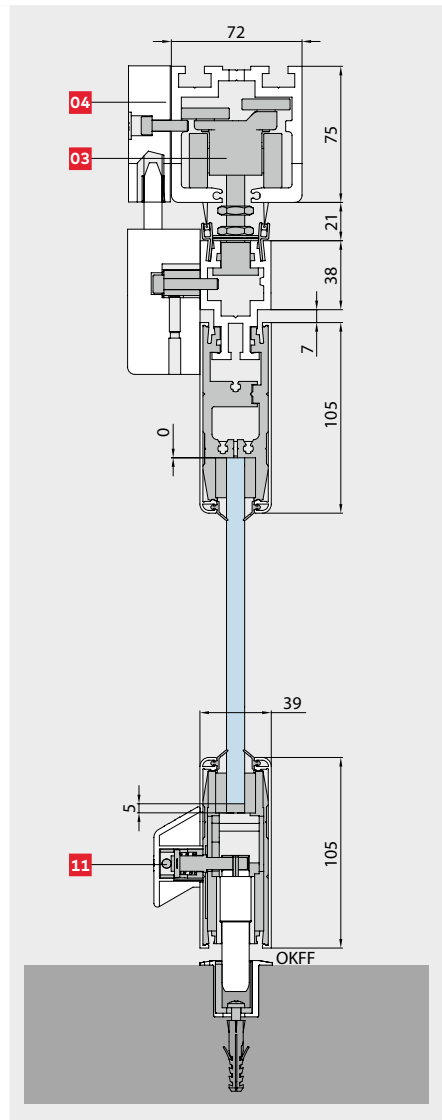

The FSW EASY Safe assembly consists of the following basic components:

- 01** Track rail (fixed to the substructure)
- 02** Upper pivot bearing
- 03** Roller carrier
- 04** Upper locking bolt
- 05** Carrier profile
Design without a carrier profile also available – see drawing below
- 06** Folding hinge
- 07** Top door rail (consisting of basic profile and covers with lip seal)
- 08** Bottom door rail (consisting of basic profile and covers with lip seal)
- 09** Toughened safety glass, or LSG of TSG (when using LSG we recommend the Clamp&Glue technology)
- 10** Floor pivot bearing
- 11** Face mounted slide bolt

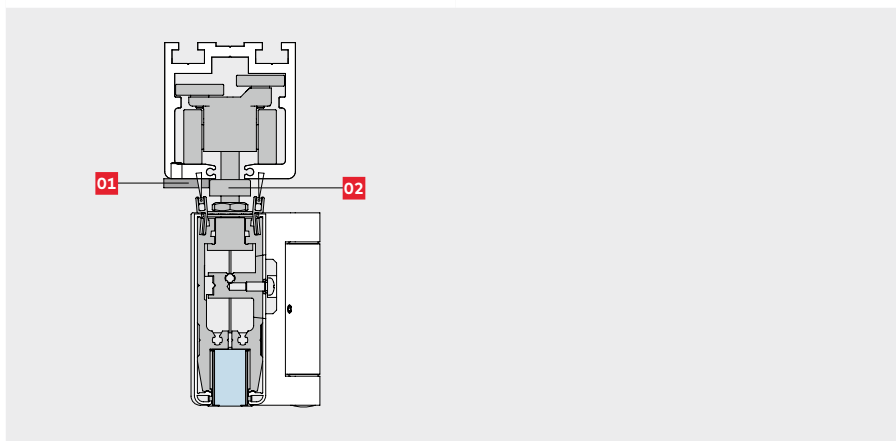
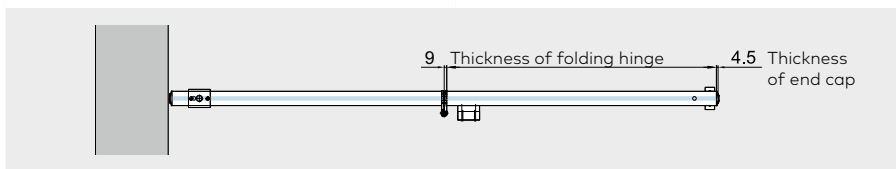

- 01** Contact plate
- 02** Roller carrier with stop device

Layout variants

Type 1

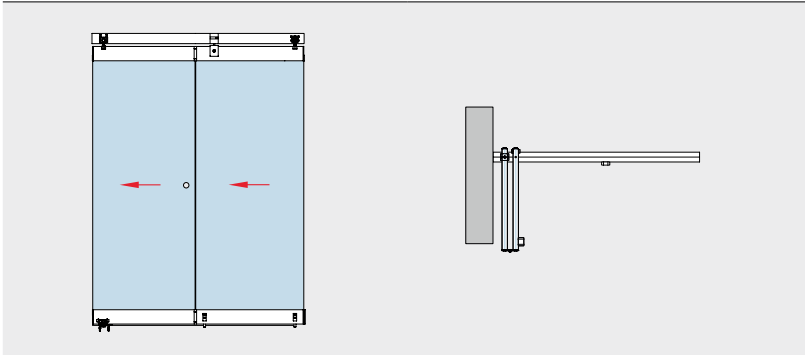

Classification Product description

- 1a** 2 panels left, as illustrated
- 1b** 2 panels right, invers
- 1c** 4 panels (2 panels left and 2 panels right), bi-parting

Type 2

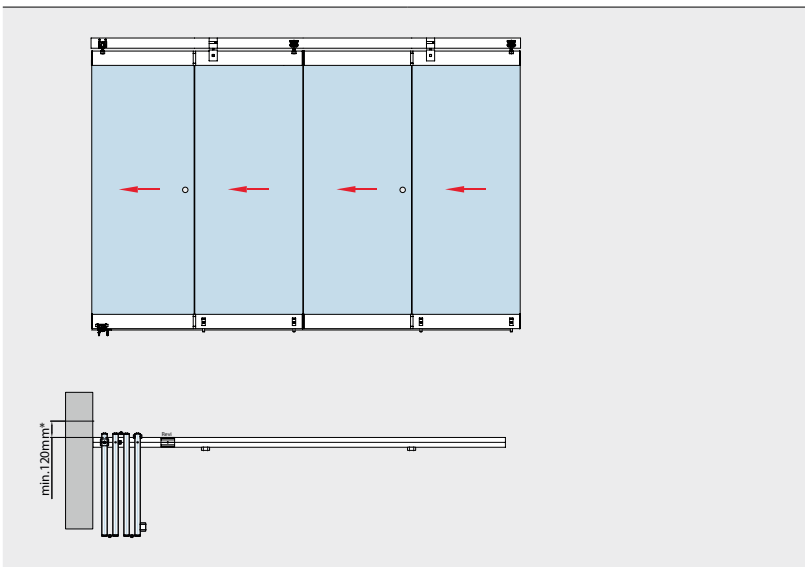

Classification Product description

- 2a** 4 panels left, as illustrated
- 2b** 4 panels right, invers
- 2c** 8 panels (2 panels left and 4 panels right), bi-parting

Type 3

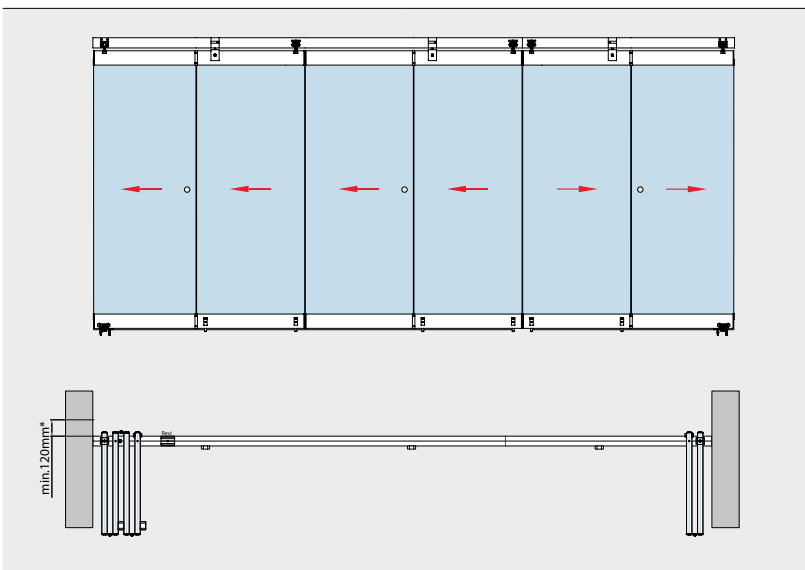

Classification Product description

- 3a** 6 panels left, as illustrated (4 panels left and 2 panels right)
- 3b** 6 panels left, invers (2 panels left and 4 panels right)

* Minimum structural clearance (e.g. balustrade, railings etc.)

Type 4

Classification Product description

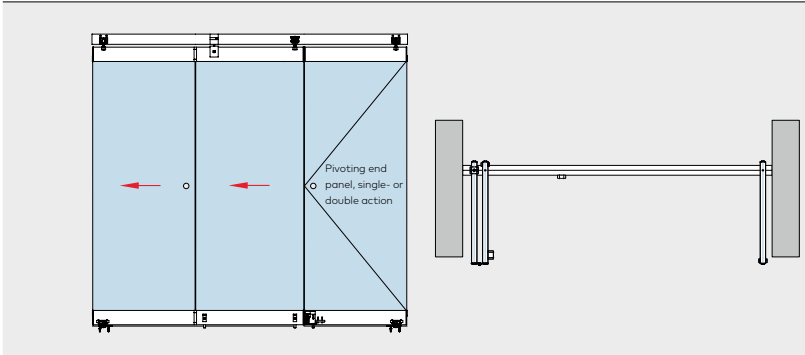

4a 2 panels left and 1 pivoting end panel, single- or double action, right (as illustrated)

4b 2 panels right and 1 single- action or double-action end panel left (invers)

Type 5

Classification Product description

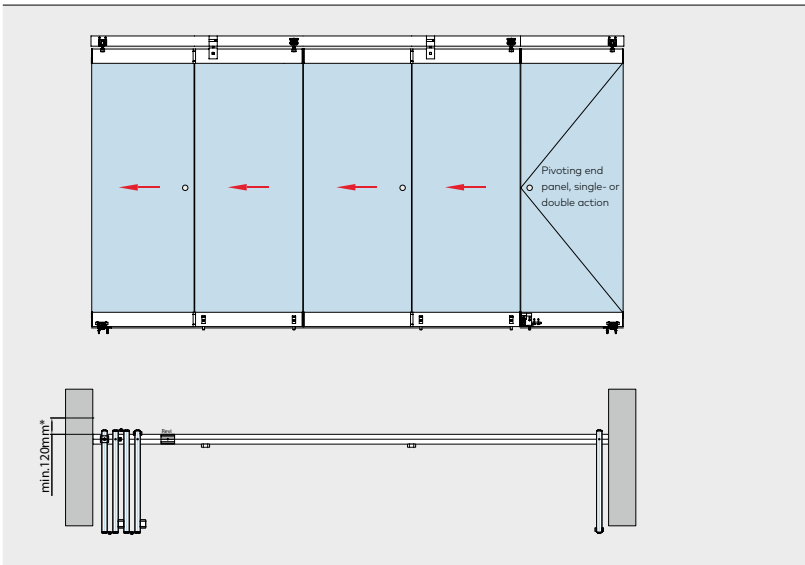

5a 4 panels right and 1 pivoting end panel, single- or double action, right (as illustrated)

5b 4 panels right and 1 pivoting end panel, single- or double action, left (invers)

* Minimum structural clearance (e.g. balustrade, railings etc.)

Types and functions

Toughened glass folding partitions with door rails top and bottom roller carrier at panel centre

The FSW EASY Safe C is adaptable to large spans. An assembly comprises a basic panel, up to 6 folding centre panels and a folding pivoting panel which, when the system is closed, can be used for access (alternatively, a non-attached single or double action end panel can be used). The number of panels therefore ranges between 3 and 8. As the roller carriers are centrally arranged on the centre panels, the basic

panel must be designed as a half-width unit (plus pivot offset of 65 mm). The pivoting access panel can be of either basic panel or centre panel width. The slightly offset hinges mean that the panels can be folded into particularly compact stacks, with high stability also ensured. Available as standard for glass thicknesses of 10 or 12 mm. Other glass thicknesses and models with laminated safety glass also available on request. Please indicate your requirements when ordering!

Example: Partition type C2 (symmetrical with narrow pivoting access panel)

- 01**
Pivot bearing top and bottom
- 02**
Basic panel
- 03**
Track rail
- 04**
Roller carrier
- 05 + 07**
Flap panel unit
- 06**
Folding hinge

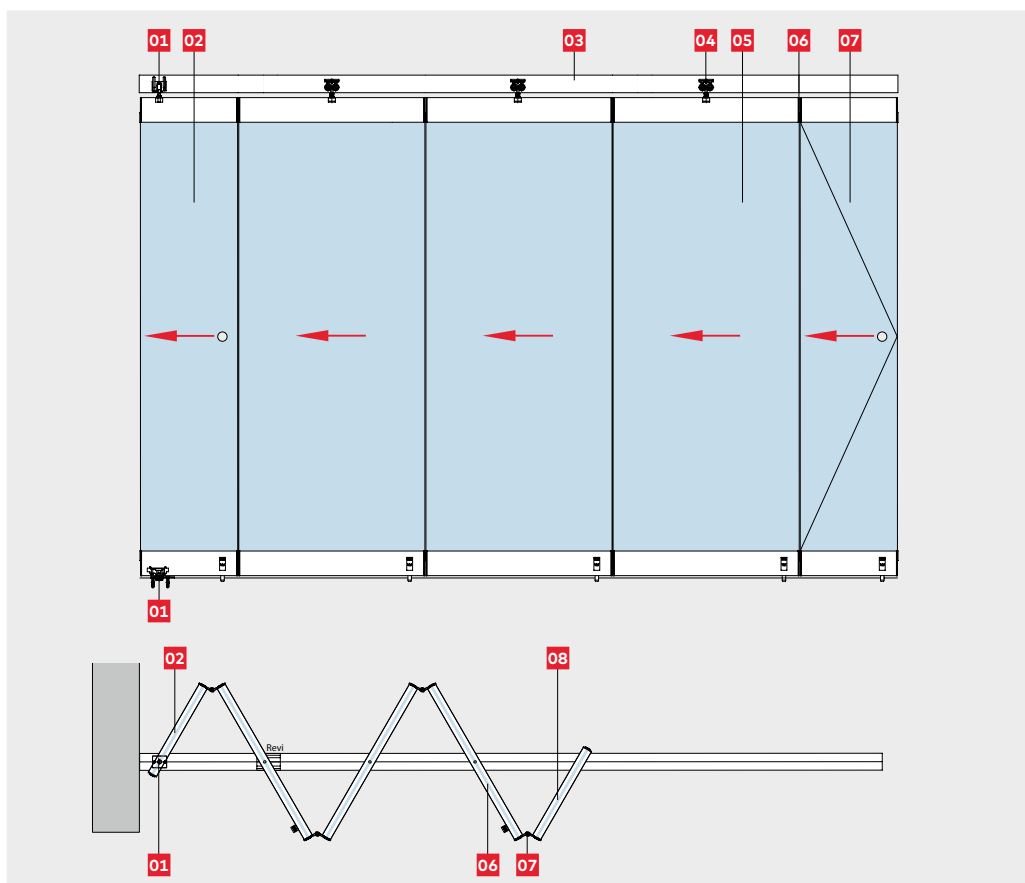

Max. panel sizes and weights	Basic panel with top pivot and floor pivot	Centre panel with roller carrier and lock bolts top and bottom	Centre panel with roller carrier and lock bolts top and bottom	Flap panel unit
Max. assembly height	3000 mm	3000 mm	3000 mm	3000 mm
Max. panel width	½ panel width + 65mm	1100 mm	1100 mm	1100 mm
Max. panel weight	80 kg	80 kg	80 kg	80 kg

The standard thicknesses are 10/12 mm toughened safety glass (TSG). Other thicknesses and glazing with laminated safety glass (LSG) available on request.

System components

Folding panel with bolt

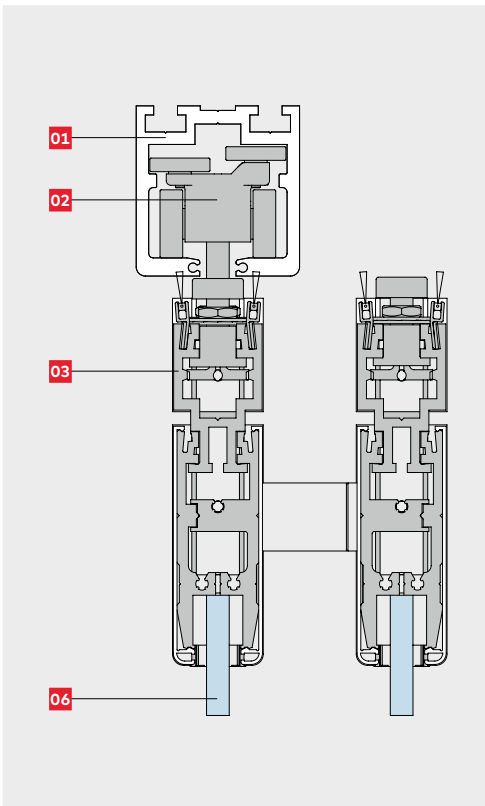

Magnetic door holders top and bottom

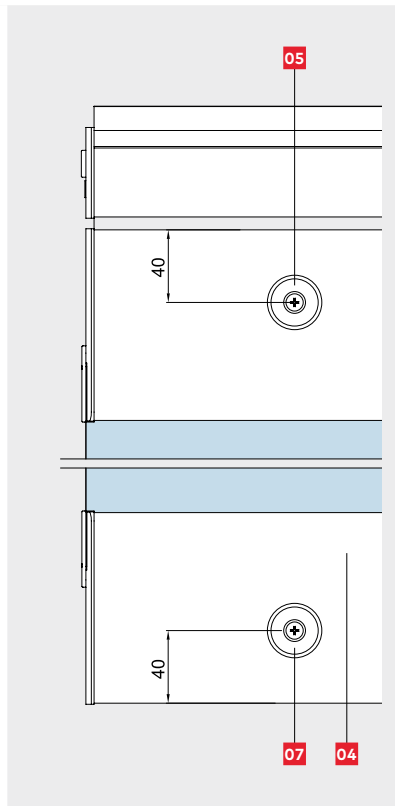

The FSW EASY Safe C system consists of the following basic components:

- 01** Track rail (fixed to the substructure)
- 02** Roller carrier
- 03** Carrier profile
Top door rail also available in a design without the carrier profile – see drawing below.
- 04** Bottom door rail consisting of basic profile and covers with lip seal.
- 05** Magnetic holder top
- 06** Toughened safety glass, or LSG of TSG (when using LSG we recommend the Clamp&Glue technology)
- 07** Magnetic holder bottom

Bottom hinge

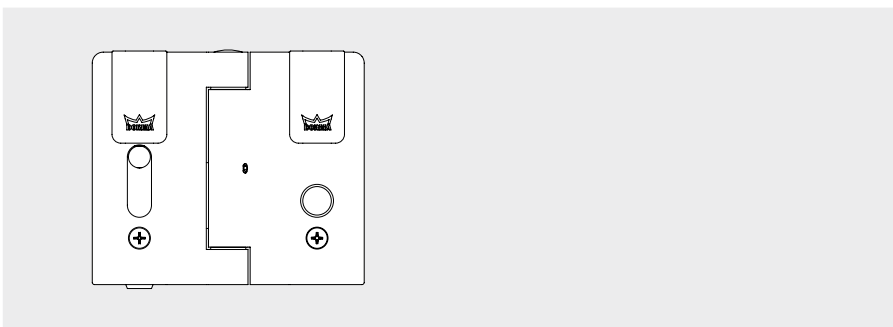

End mounted slide bolt at the bottom between both panels of the flap panel unit

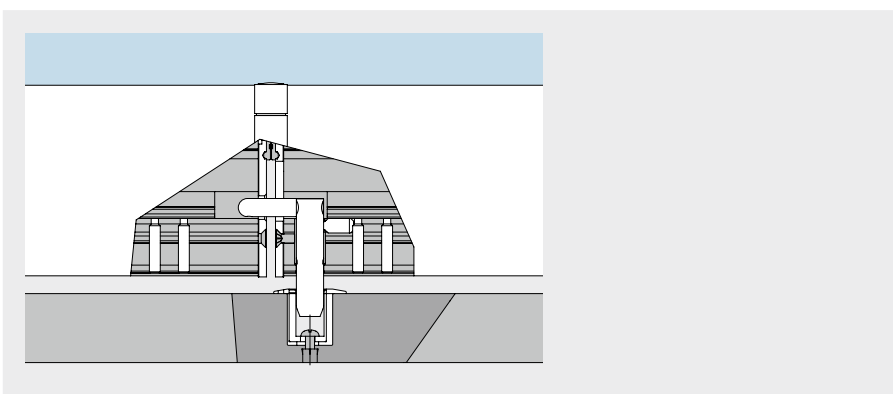

Layout variants

Type C1

Product description

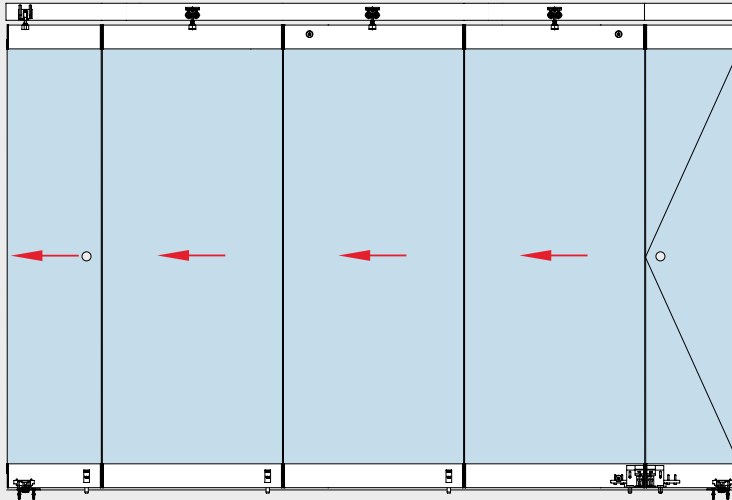

- 1 pivoting end panel, single-action, as access (here in narrow design for reasons of symmetry)
- 1-6 centre panels
- 1 basic panel (narrow)

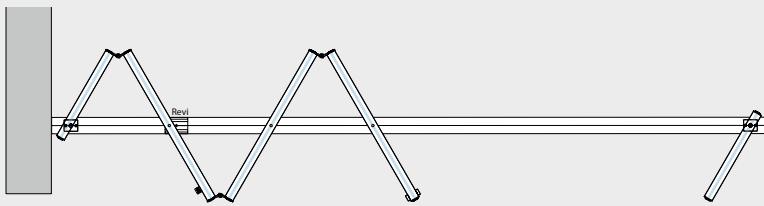

Type C2

Product description

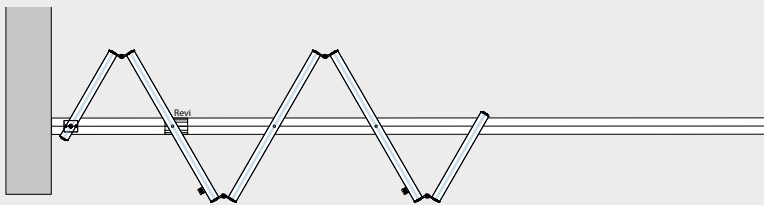

- 1 pivoting access panel (here in narrow design for reasons of symmetry)
- 1-6 centre panels
- 1 basic panel (narrow)



Type C3

Product description

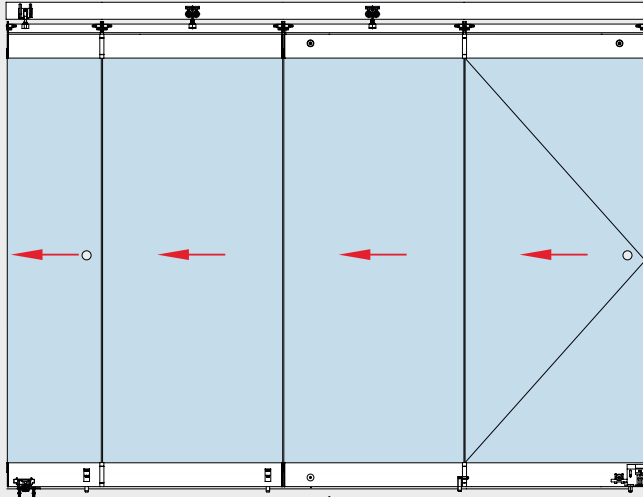

- 1 basic panel (narrow)
- 1-5 centre panels
- 1 dual panel assembly

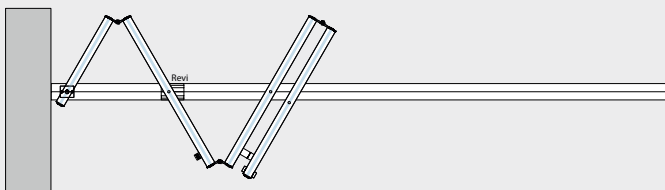

Type C3, dual assembly (bi-parting)

Product description

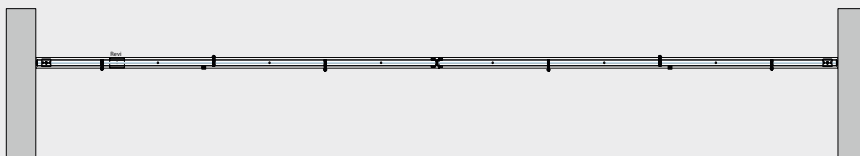

- Left:**
- 1 basic panel (narrow)
 - 1-5 centre panels
 - 1 dual panel assembly

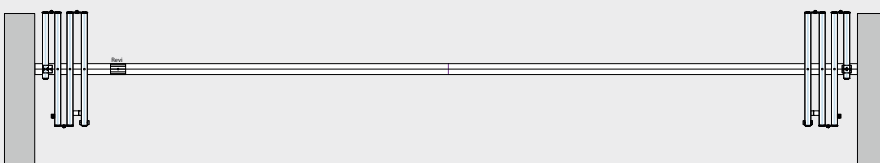

- Right:**
- 1 basic panel (narrow)
 - 1-5 centre panels
 - 1 dual panel assembly

Types and functions

Access with convenience – the plus you get with the FSW EASY Safe Cplus

Based on the design of the FSW EASY Safe Cplus, the model variant FSW EASY Safe Cplus offers the possibility of including a flap panel as a fully fledged access door when the system is otherwise closed – with all the automatic closing convenience which the DORMA TS 93 G cam-action door closer can offer. The special

bottom lock bolt and the top clamp-fitted stop serve to stabilize the first panel of the flap panel unit in this configuration. The top angle stop ensures the correct positioning of the closed flap panel unit. The folding hinges connect both panels of the flap panel unit and offer a larger pivot offset in order to create space for the door closer and pull handles. All the other folding panels are equipped with standard hinges and roller carriers.

Type Cp 1

Product description

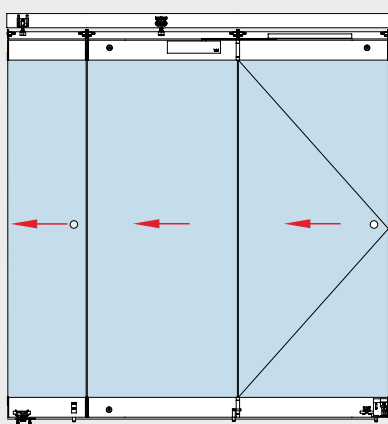

- 1 basic panel (narrow)
- 1 dual panel assembly with TS93 G cam-action door closer

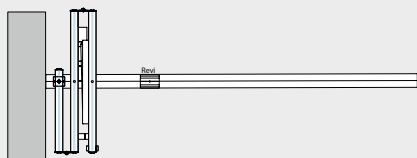
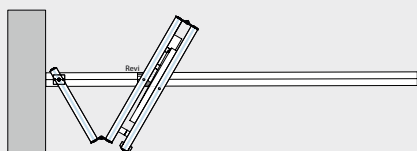
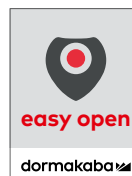

Type Cp1 dual assembly (bi-parting)

Product description

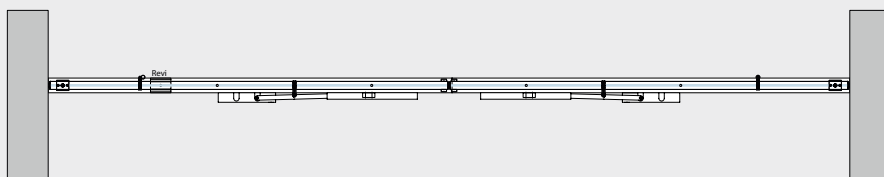

- Left:**
- 1 basic panel (narrow)
 - 1 dual panel assembly with TS93 G cam-action door closer

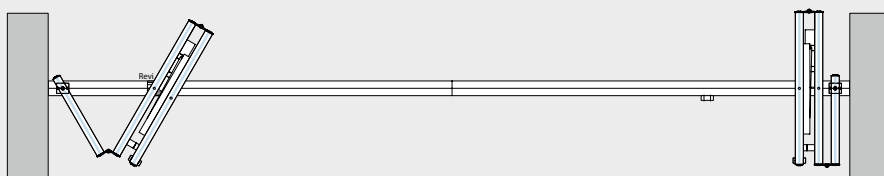

- Right:**
- 1 basic panel (narrow)
 - 1 dual panel assembly with TS93 G cam-action door closer

Type Cp 2

Product description

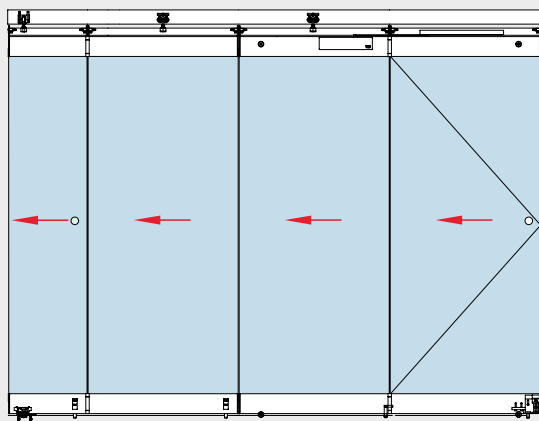

- 1 basic panel (narrow)
- 1 – 5 centre panels
- 1 dual panel assembly with TS93 G cam-action door closer

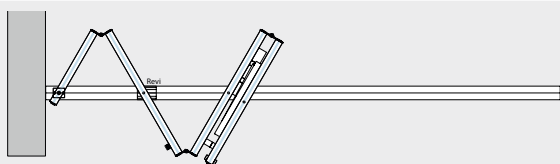
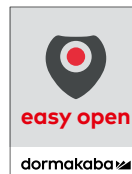

Type Cp2, dual assembly (bi-parting)

Product description

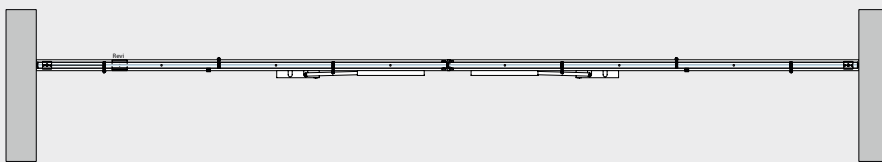

- Left:**
- 1 basic panel (narrow)
 - 1 – 5 centre panels
 - 1 dual panel assembly with TS93 G cam-action door closer

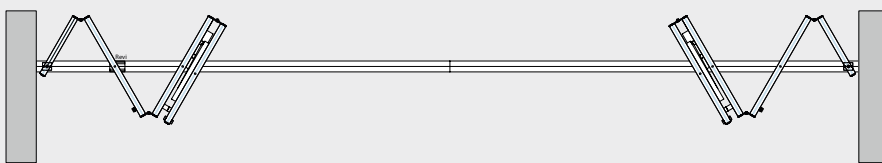

- Right:**
- 1 basic panel (narrow)
 - 1 – 5 centre panels
 - 1 dual panel assembly with TS93 G cam-action door closer

TS 93 technical data and features

Spring strength/Door closer size	EN 2 – 5	EN 5 – 7
Adjustable closing force	Adjustable screw	Adjustable screw
Adjustable closing speed	Adjustable valve	Adjustable valve
Non-handed	Yes	Yes
Adjustable latching action	Adjustable valve	Adjustable valve
Adjustable backcheck	80° – 120°	80° – 120°
Adjustable hold-open	75° – 150°	75° – 150°
Weight	3.5 kg	5.2 kg
Length	275 mm	285 mm
Installation depth	53 mm	62 mm
Height	60 mm	71 mm

HSW-GP panels and functions

Fully glazed sliding walls, point-fixed with standard track rail.

The characteristic features of HSW-GP systems are the single-point fixings of the glass panels in combination with a conventional track rail profile. The design, featuring a high-grade stainless steel finish and the distinctive flush-mounted or clamping disc attachments, coordinates perfectly with contemporary architecture. Even curved glazing can be securely held by this system. And this can also be combined with curved track rail profiles to produce unique configurations. Combined with curved track rail profiles special system configurations can be enabled. The standard glass thickness is 10/12 mm. Further glass thicknesses on request.

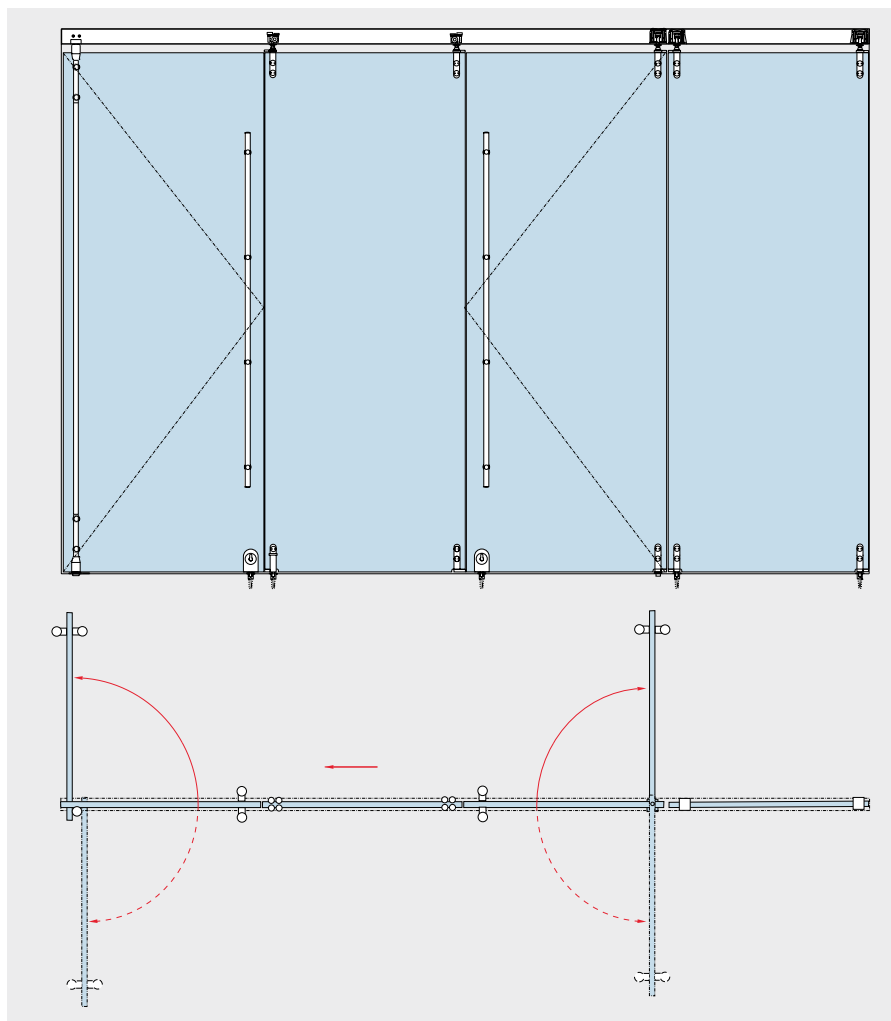

Max. panel sizes and weights	Pivoting end panel, single- or double-action	Sliding panel	Pivoting end panel, single- or double-action	Fixed panel
	Non-sliding. With full-length pivot rod and offset pivot. Single-action panel with floor pivot, round spindle and stop. Double-action panel with floor pivot or BTS floor spring.	Fixed when frontage closed.	Non-sliding. With centre pivot top and bottom. Single-action panel with floor pivot, round spindle and stop. Double-action panel with floor pivot.	Non-sliding. Fixed side panel with retaining pins at the top and fixed panel straps at the bottom.
Max. system height	3,000 mm*	3,000 mm	3,000 mm*	3,000 mm
Max. panel width	1,200 mm	1,200 mm	1,200 mm	1,200 mm
Max. panel weight	100 kg	100 kg	100 kg	100 kg

The track roller position cannot be varied. The width of all panels in the system must be uniform.
 * From a panel height of 2,500 mm, we recommend a continuous pivot rod extending over the full height of the panel.
 From a panel height of 2,700 mm, we recommend a fifth single-point fixing.

System design

Sliding panel with bottom end-mounted pin

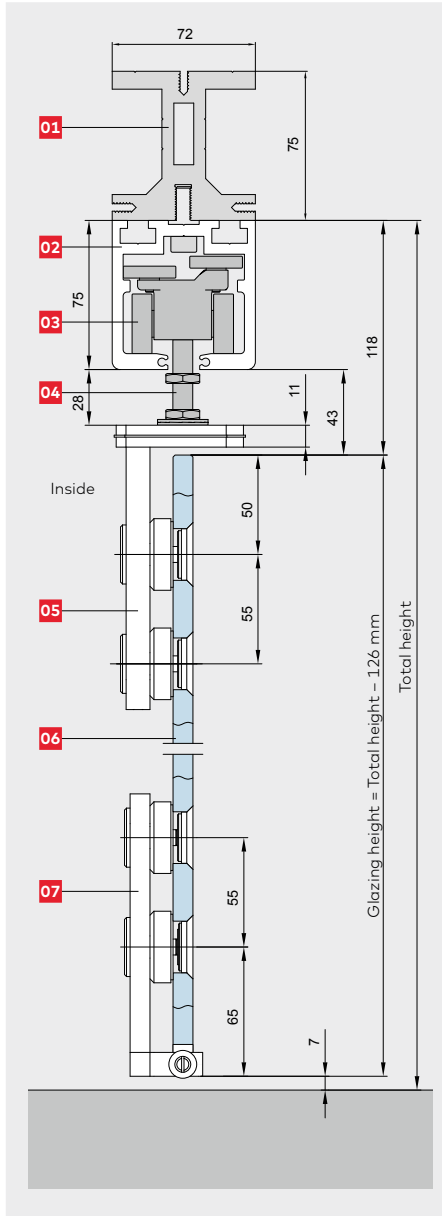

Sliding panel with bottom face-mounted slide bolt

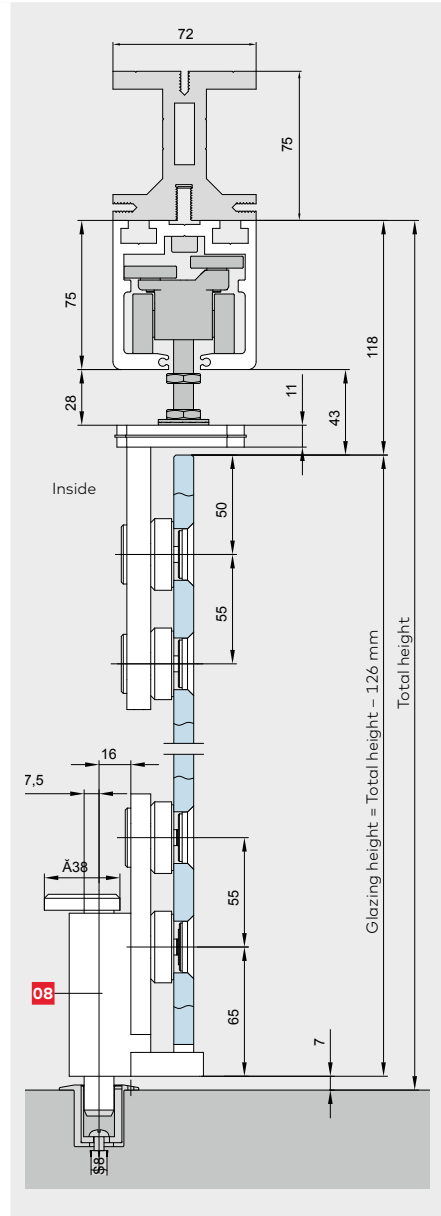

The HSW-GP system consists of the following basic components:

- 01** installation-efficient dormakaba substructure to accommodate track rail mounting requirements (optional).
- 02** track rail (for bolting to the substructure).
- 03** roller.
- 04** roller bolt.
- 05** strap with single-point fixings.
- 06** toughened safety glass or toughened laminated safety glass (by others).
- 07** bottom strap with end-mounted pin.
- 08** bottom strap with face-mounted slide bolt.

Types and glass preparation

Pivoting end panel, single- or double-action, with pivot rod

Glass preparation

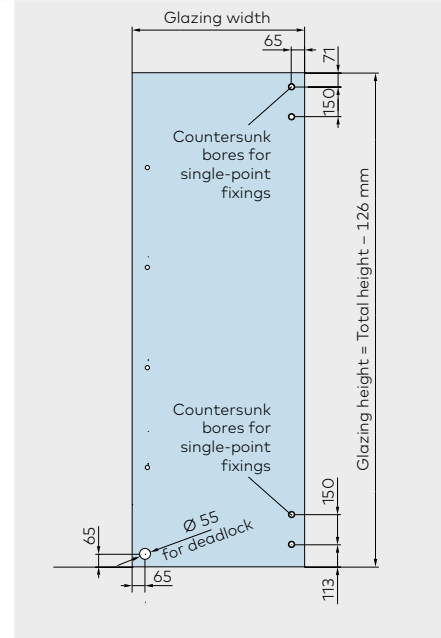
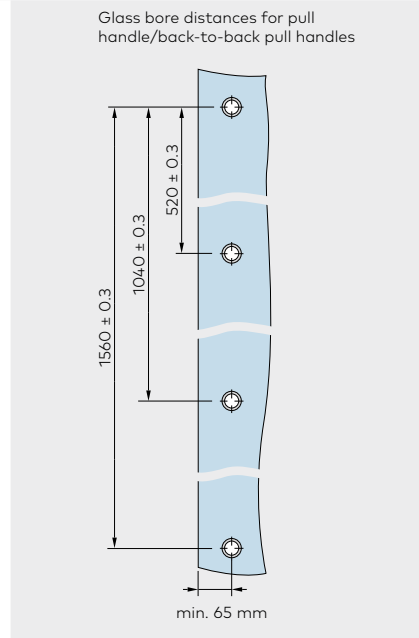
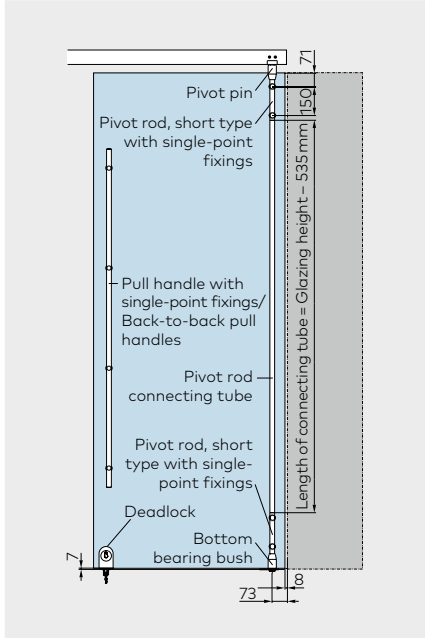

Pivoting end panel, single- or double-action

Glass preparation

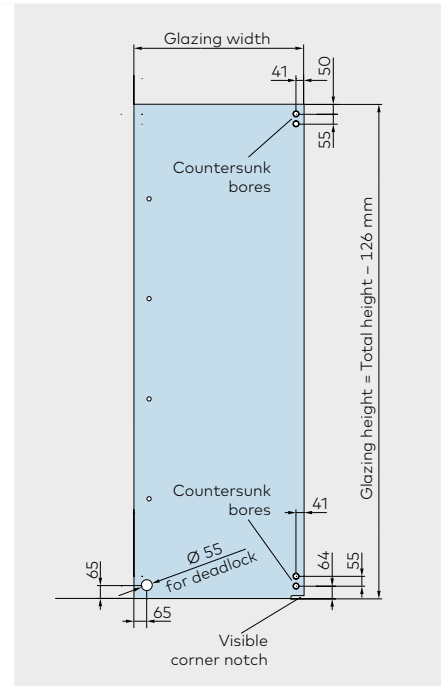
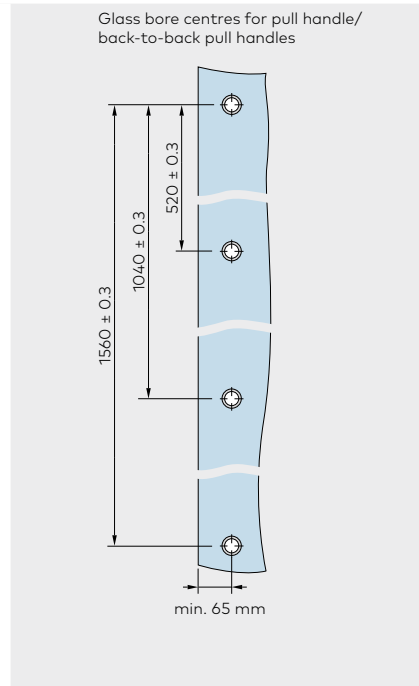
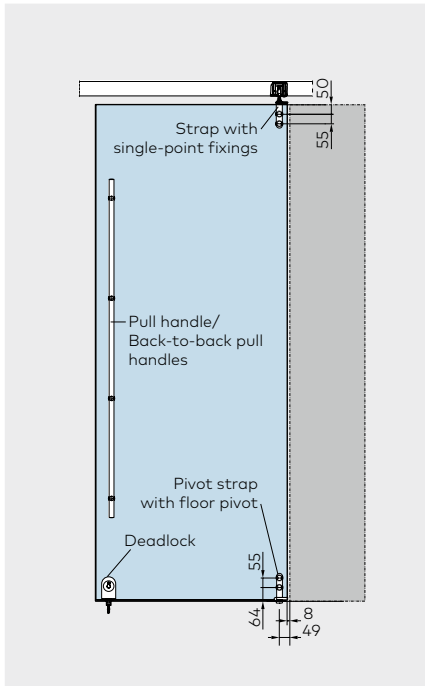

Sliding panel

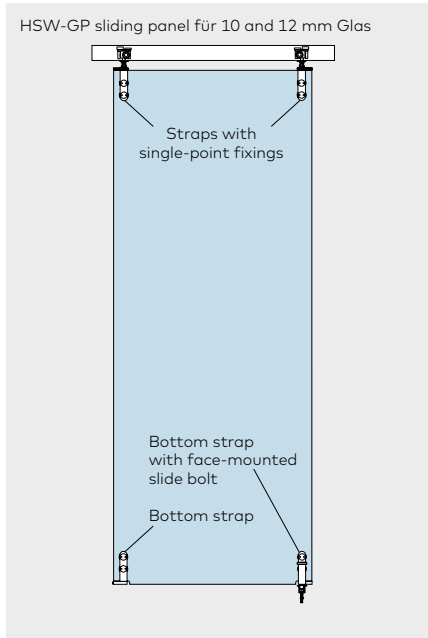

Fixed panel

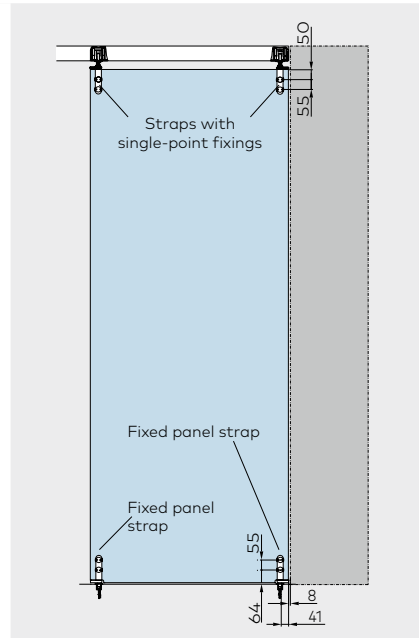

Glass preparation

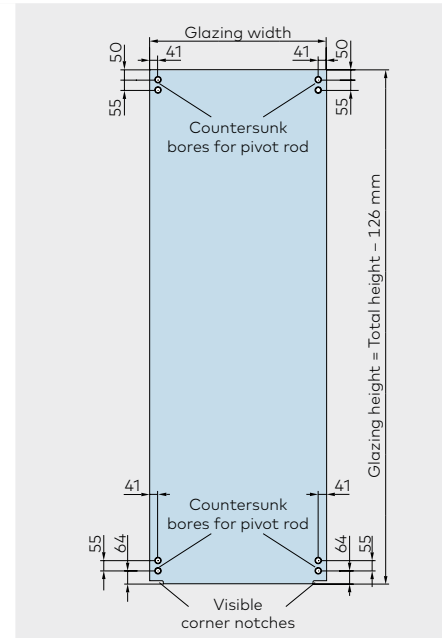

Glass bores and notches

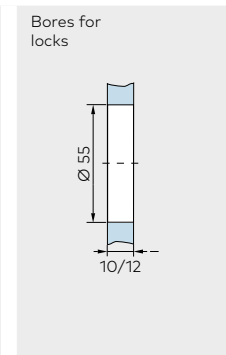
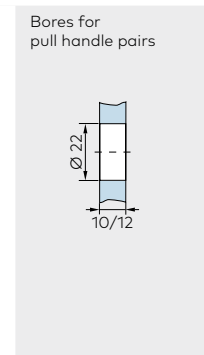
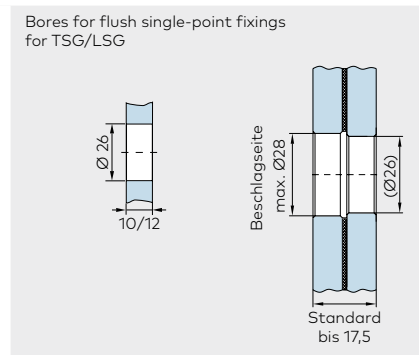
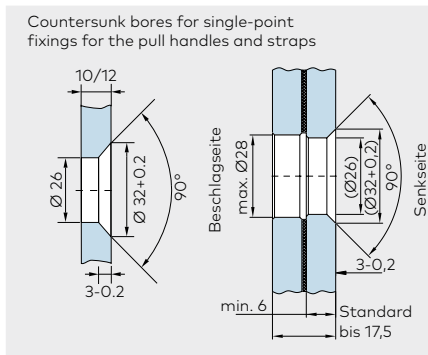

Special step

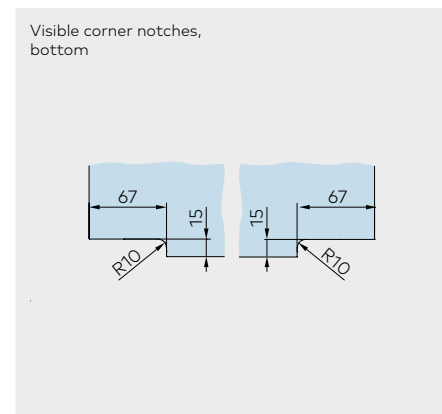
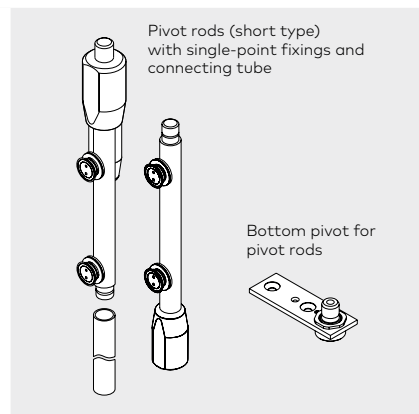
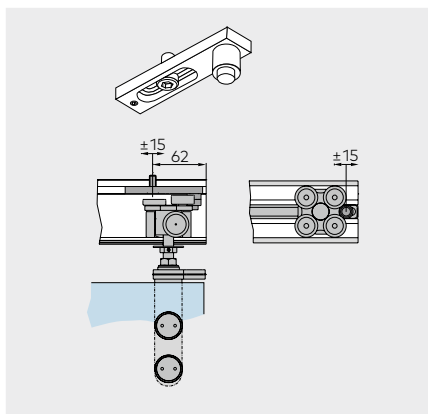

Types and functions

Horizontal sliding walls, framed all round for toughened safety glass, laminated safety glass or double glazed units

Resistant to mechanical stress, protect against the influences of the weather, heat loss and drafts thanks to sturdy profile frames with brush seals top and bottom and laterally arranged rubber lip seals. Optionally prepared for single pane toughened safety glass (TSG) or laminated safety glass (LSG), insulating glass/ double glazing or special glass. Frame profiles for 8 to 24 mm. Other glass thicknesses on application.

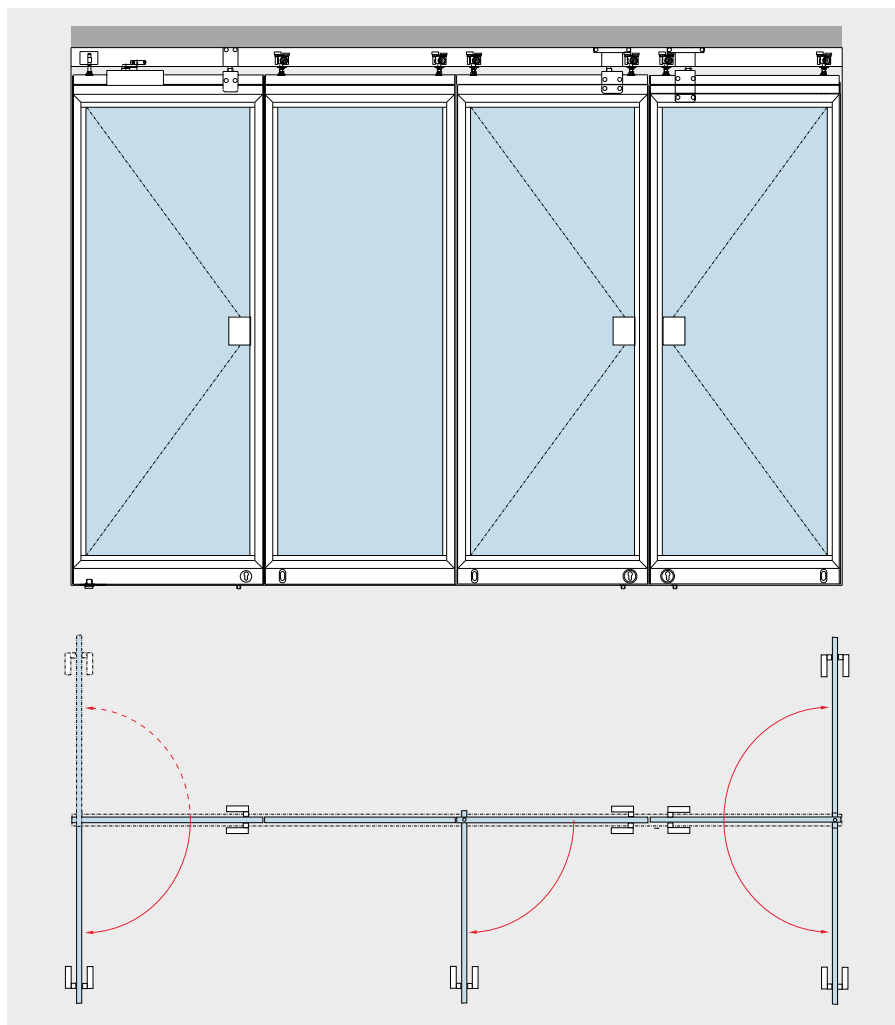

Max. panel sizes and weights	Pivoting end panel, single- or double-action Non-moving. Pivoting end panel, double-action, with floor bearing and top pivot. Optional with floor spring BTS 80/84. Or as pivoting end panel, single-action, with stop and BTS 80/84 or TS 92/TS 73.	Sliding panel Fixed when frontage closed.	Pivoting end panel, When frontage closed with integrated concealed door closer type ITS 96, Size 3-6; operational. Minimal panel width 870 mm.	Double-action sliding panel* When frontage closed with integrated concealed door closer type ITS 96, Size 3-6; operational. Minimal panel width 870 mm.
Max. system height	3,000 mm	3,000 mm	3,000 mm	3,000 mm
Max. panel width	1,100 mm	1,100 mm	1,100 mm	1,100 mm
Max. panel weight	100 kg	100 kg	100 kg	100 kg

The individual panels can also be of differing widths. The largest width should not exceed max. 115% of the smallest width.

* For these panel types please consider our notes on portal systems on page 107.

System design

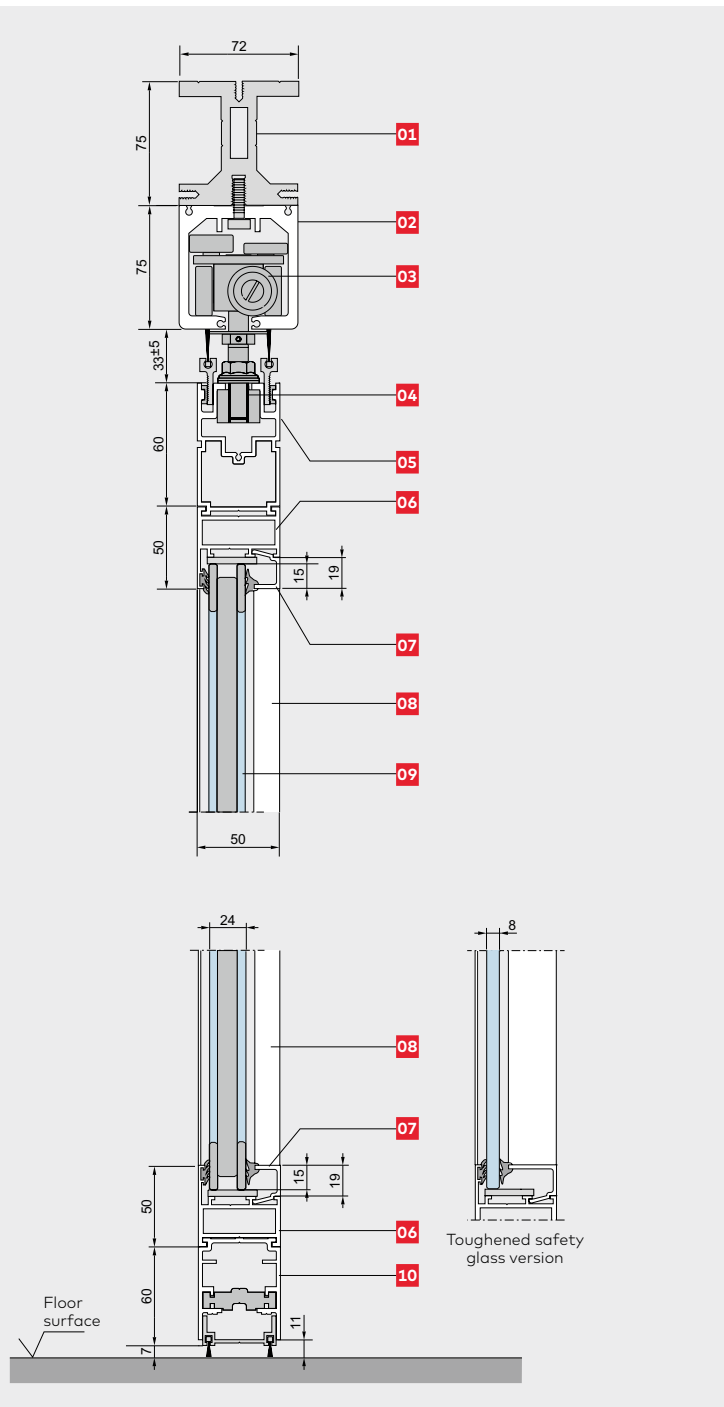

Irrespective of the function of the individual panels, an HSW-R system comprises the following components:

- 01**
Installation-efficient dormakaba substructure to accommodate track rail mounting requirements (optional)
- 02**
Track rail (for bolting to the substructure)
- 03**
Carrier
- 04**
Suspension assembly
- 05**
Adapter frame
- 06**
Glazing frame profile, horizontal
- 07**
Glass clamping bar
- 08**
Glazing frame profile, vertical
- 09**
Toughened safety glass, laminated safety glass or double glazing units (by others)
- 10**
Bottom frame profile.

Single/double-action panels

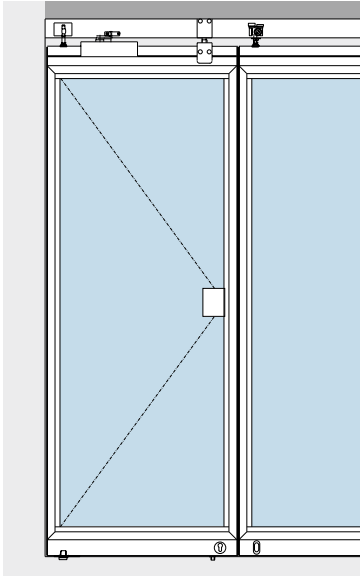

Pivoting end panel, single- or double-action, with floor pivot
 Non-moving and always equipped with bottom dead-bolt with the option of a top bolt or side action deadlock. Single-action or double-action options.

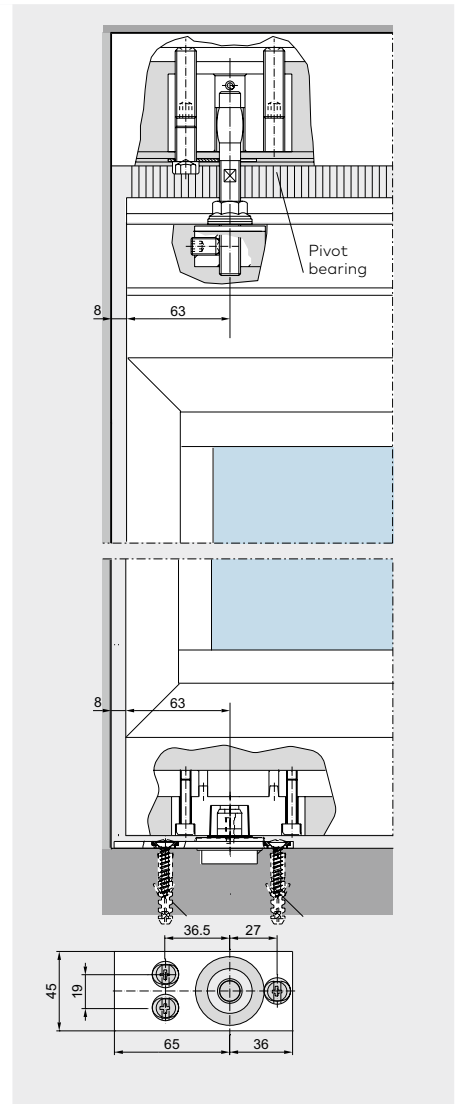
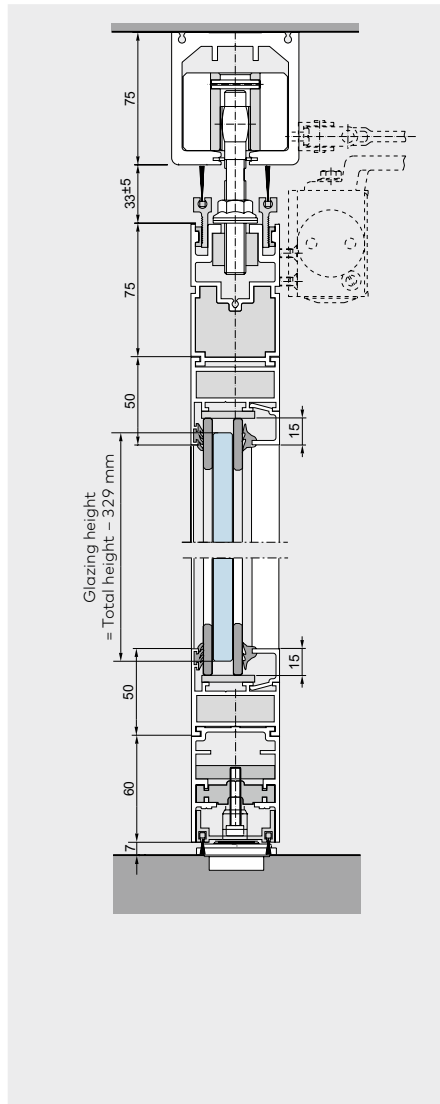

Pivoting end panel, single-action

with stop plates at the top bolt.

Assembly types:

- Floor pivot with round spindle
- As above, but with DORMA TS 73 or TS 92 overhead door closer
- BTS 84 for panels up to 100 kg, with optional hold-open at 90° door opening angle
- BTS 80 for panels of 100–150 kg, provided with hold-open as standard

Pivoting end panel, double-action

Assembly types:

- Floor pivot with round spindle
- BTS 84 for panels up to 100 kg, with optional hold-open at 90° door opening angle
- BTS 80 for panels of 100–150 kg, provided with hold-open as standard

Pivoting end panel, single- or double-action, with floor spring

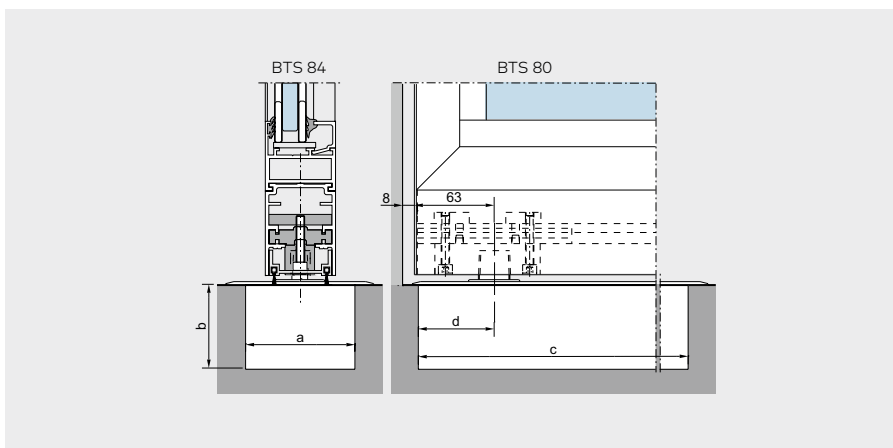

Mounting dimensions (mm)

	BTS 80	BTS 84
a	78	108
b	60	40
c	341	306
d	51–57	51–58

Pivoting end panel, single-action

with TS 73 overhead door closer and additional locking device and door stop

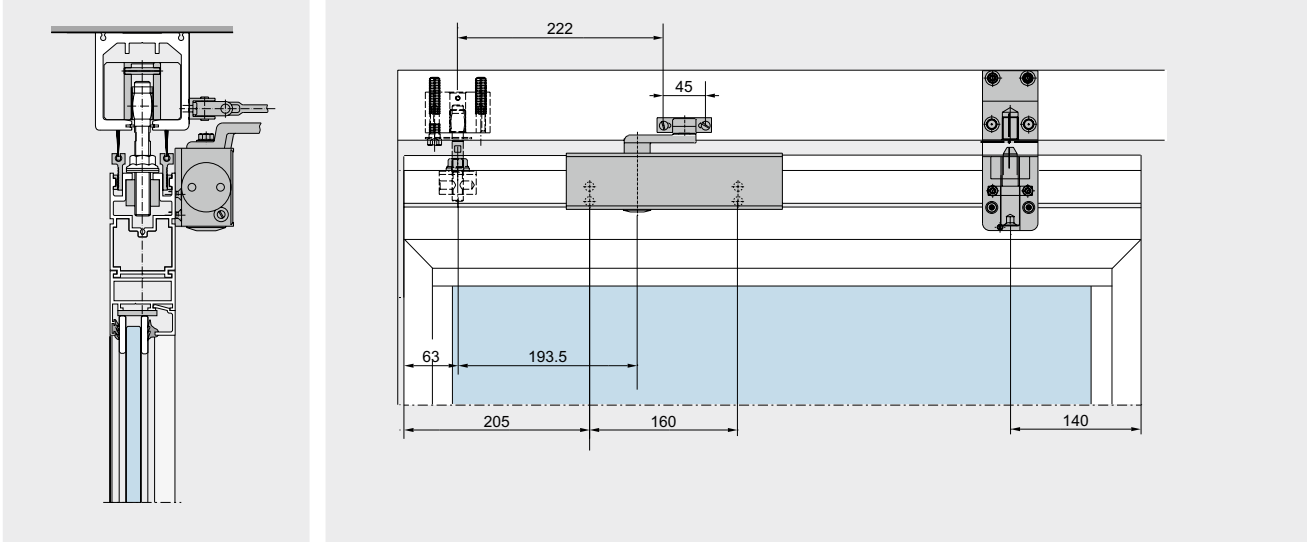

with TS 92 overhead door closer and additional locking device

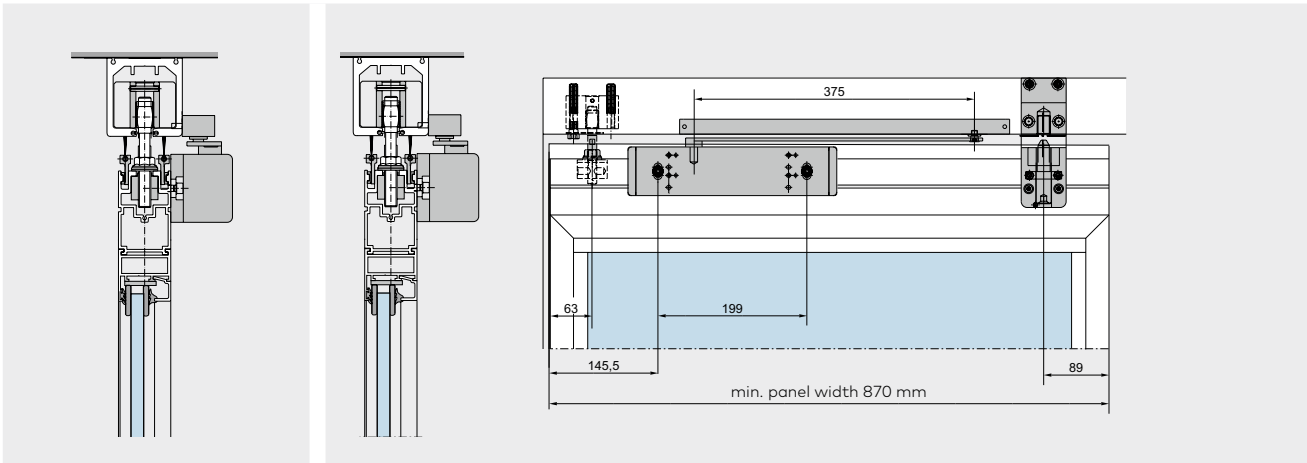

Additional locking device

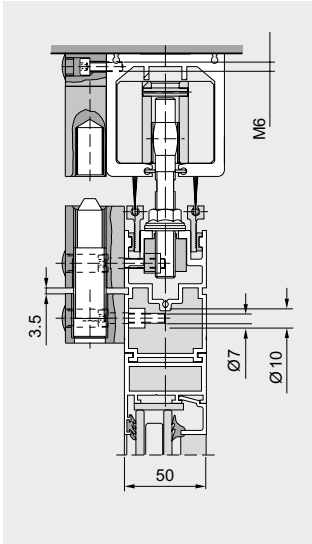

Data and features	TS 73 V	TS 92
Closing strength/size	EN 2-4	EN 2-4
Closing strength, variable	via adjusting screw and arm hing	via adjusting screw and arm hinge
Closing speed adjustment	via valve	via valve
Non-handed	●	●
Latching speed adjustment	via arm	via arm
Cushioned stay limit adjustment	75°-180°	80°-120°
Hold-open adjustment	75°-160°	75°-150°
Weight	1.8 kg	1.9 kg
Length	233 mm	281 mm
Overall depth	42.50 mm	47 mm
Height	60 mm	65 mm

Sliding panels and connections

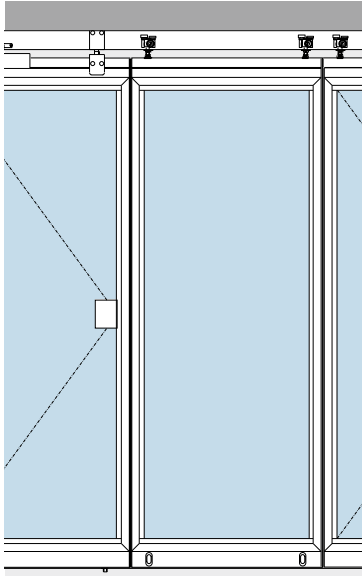

Fixed when partition is closed.

The sliding panels are moving elements. Once in their closed position, they are locked down. The components available for this are provided in the bottom rail in the form of face-mounted floor bolts or deadlocks.

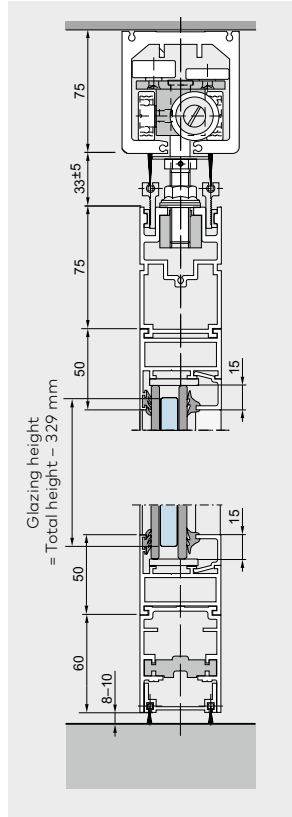

Fixing the panel in the strike plate

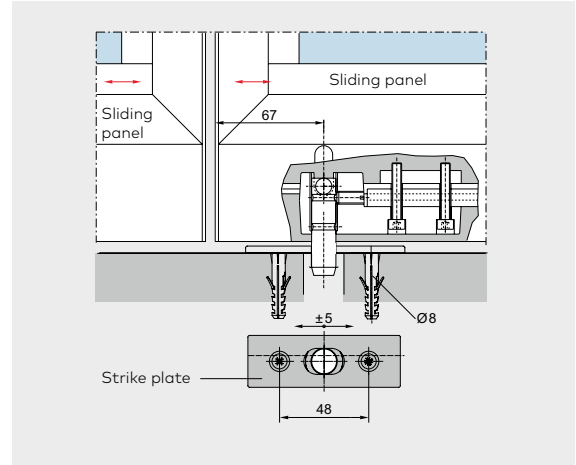

Fixing the panel in eccentric bushing

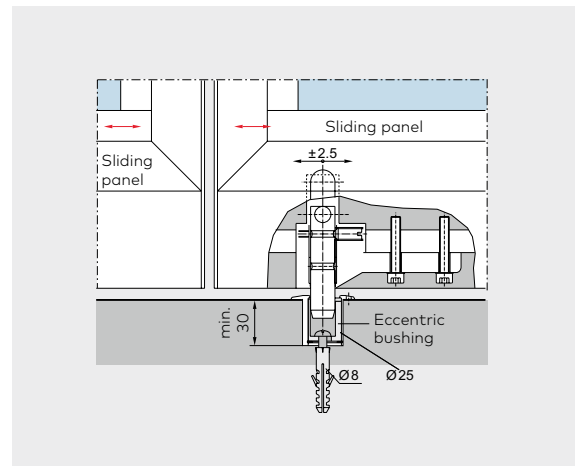

Sliding panel to panel connections

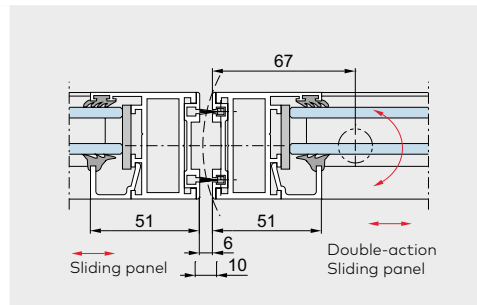
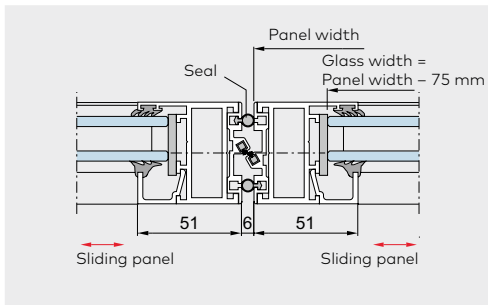

Panel to wall connection

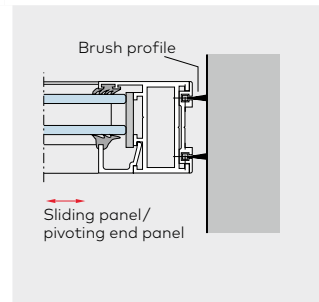
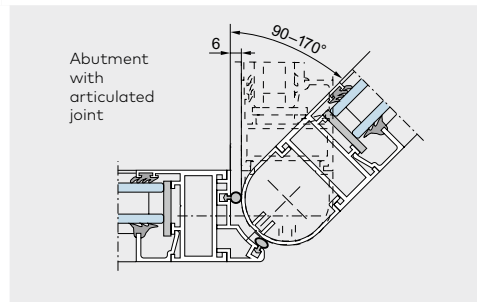
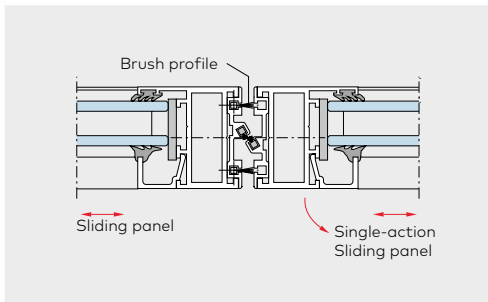
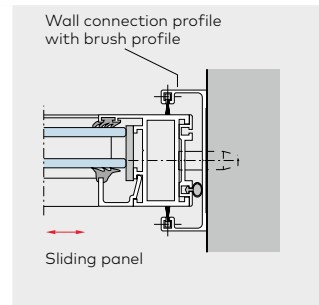

Single-action sliding panel

with integrated DORMA ITS 96 concealed door closer, size 3–6

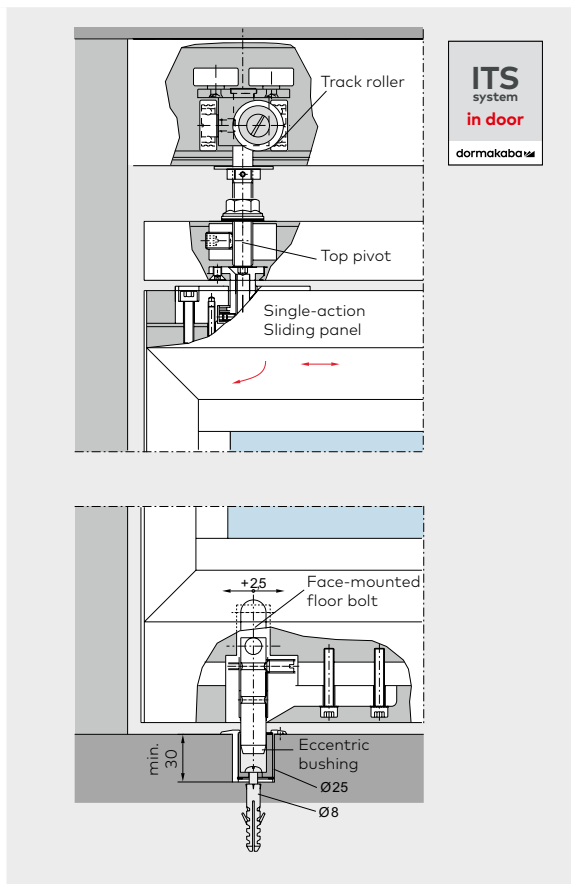
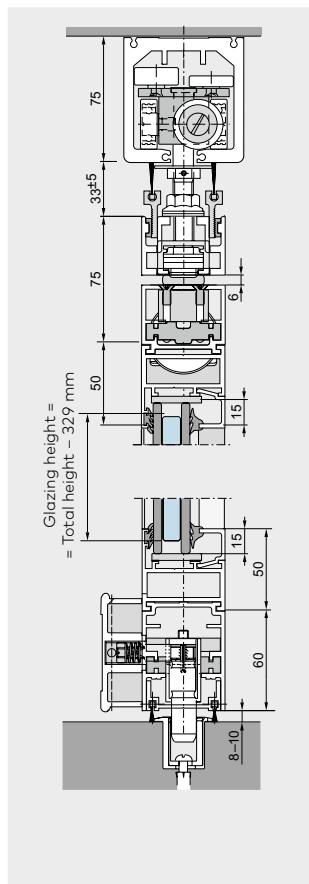
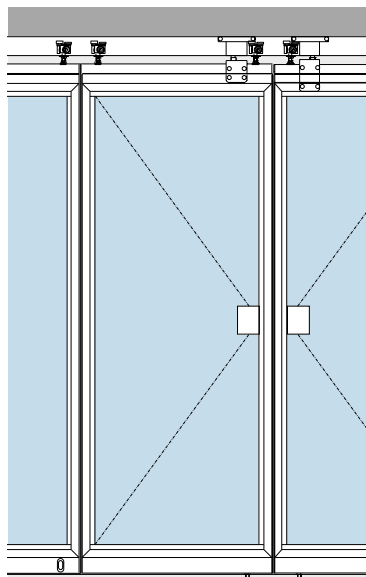

This panel type is used where passdoors only need to be opened in one direction. The single-action sliding panel can be configured for either inward or outward opening.

Standard assembly

- top: Pivot bearing, ITS 96, size 3–6, one locking device
- bottom: Face-mounted floor bolt as pivot (released for sliding function)

Optional equipment

- top: Second locking device (for reshuffle bypass stacking)
- bottom: Optional second face-mounted floor bolt or deadlock

Locking device

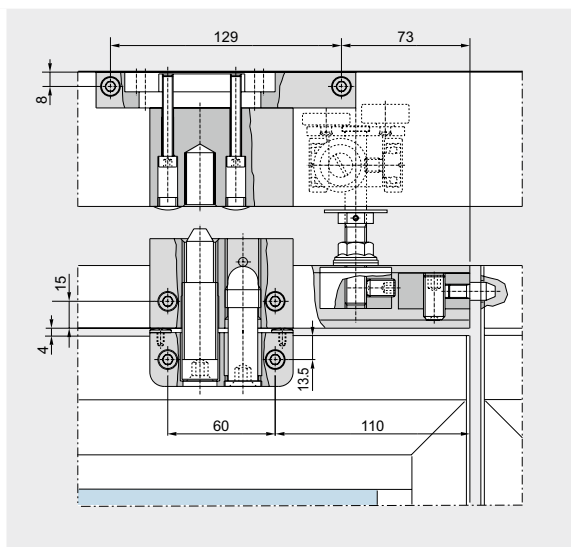
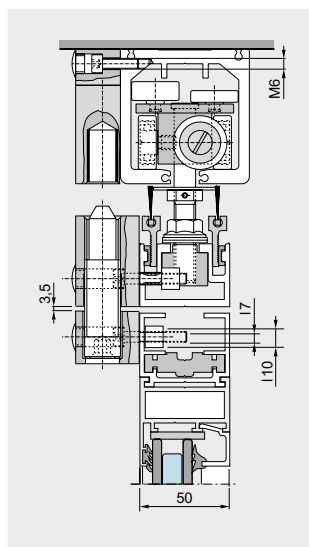

Double-action sliding panel

with integrated DORMA ITS 96 concealed door closer, size 3–6

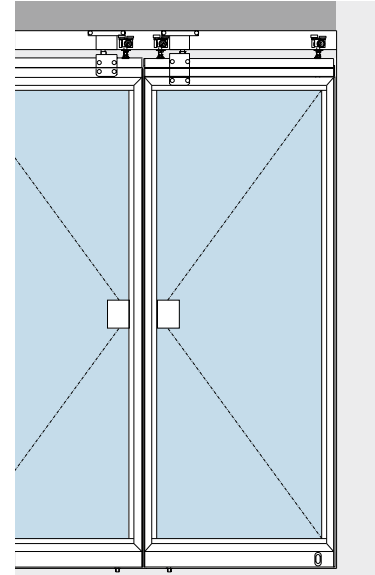
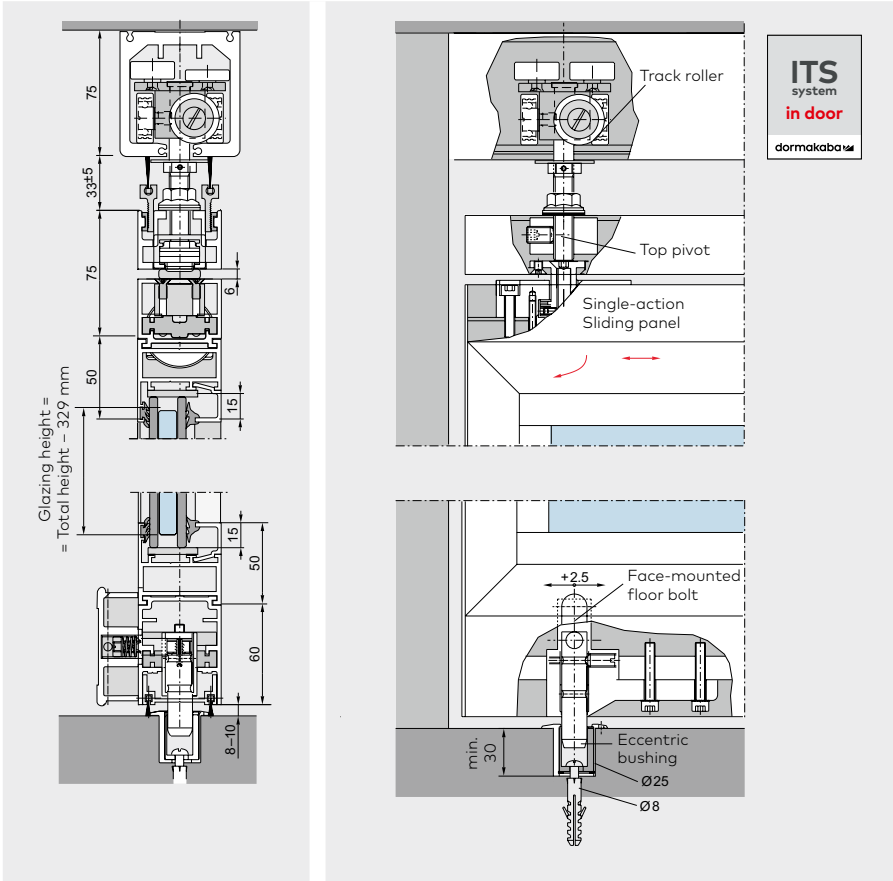

Double-action sliding panels with DORMA ITS 96, size 3–6 door closers are characterised by their exceptional ease of installation and operation. These passdoor panels are generally equipped with a bottom dead-lock and top locking device plus a bottom floor bolt operating as the pivot bearing (released for the sliding function). The ITS 96 does not feature a hold-open function as standard.

Locking device

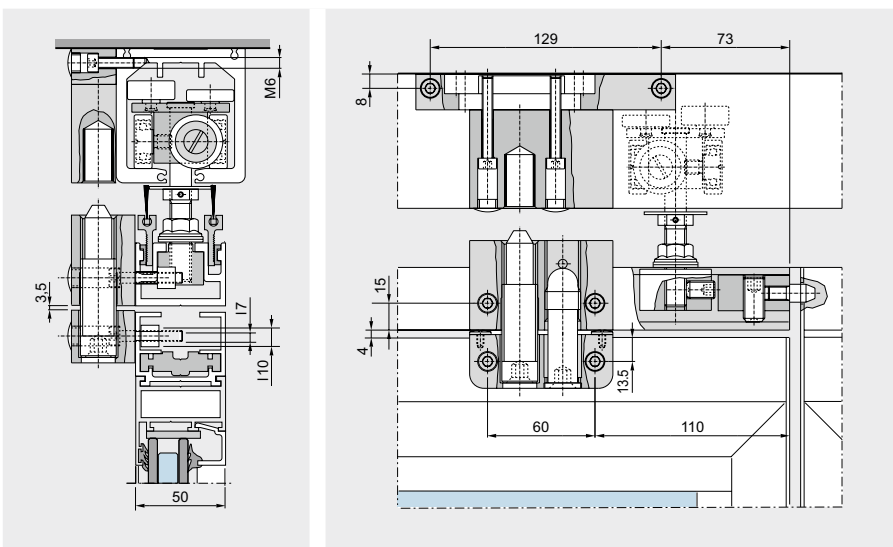

For these panel types please consider our notes on portal systems on page 107.

Content

Accessories

- 86** Vertical seals –
Overview
- 88** Vertical sealing profiles –
General preparation
- 89** Vertical sealing profiles –
Panel types
- 96** Handle bars, door knobs
and recessed pull grips



Accessories

Vertical seals – overview

With regards to material, fixing and the grade of draft-proofing different solutions are available.

Retrofittable seals

The plastics profiles shown below provide an unobtrusive and retrofittable solution for draft protection at the glass edges.

Product description

h-profile
 Push on clear plastic for 10 and 12 mm glass thickness (not for pivoting end panel, double-action, or double-action sliding panels).

Glass joint gasket
 Milky transparent rubber, self adhesive for 10–19 mm glass thickness.

Vertical sealing profiles with brushes

The aluminium sealing profiles are fixed to the full height of the panels, replacing the end caps at the top and bottom door rails. They are individually tailored to the requirements of the bottom door rails, so they are already prepared for the locking devices such as end caps, end pins when delivered by dormakaba. At the top, a degree of extra length is provided to enable pre-

cise sealing profile adaptation to the exact panel height on site once the system has been vertically aligned. The double brush seals interlock with those at the adjacent panel and continue in line with the double brush seals at the top and bottom door rails. This ensures excellent draft proofing.

Product description

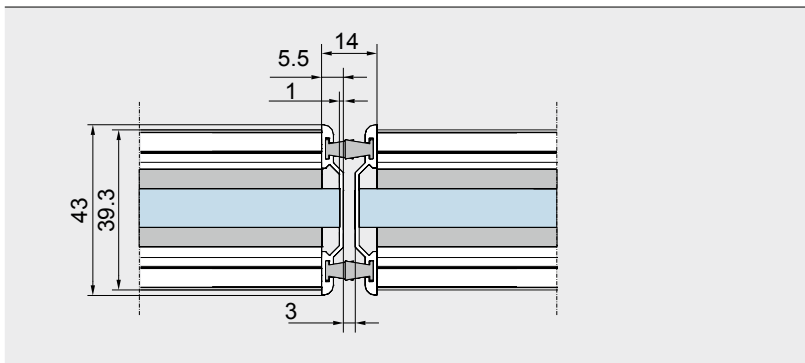

Vertical sealing profile

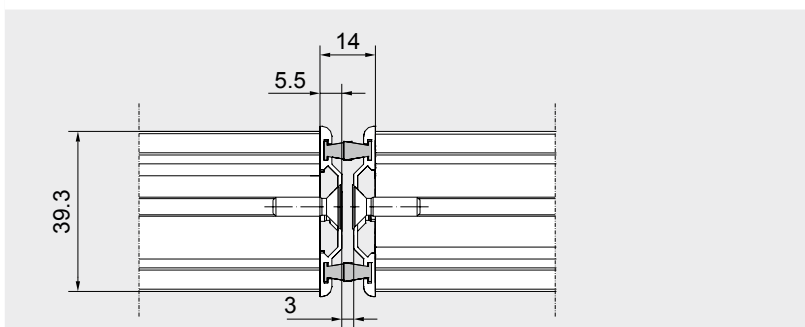

Vertical sealing profile

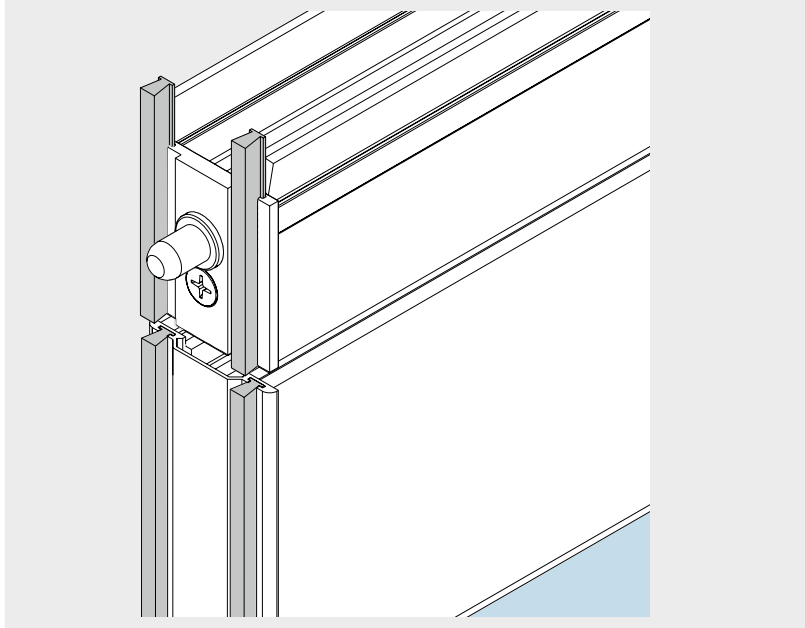

Vertical sealing profiles – general preparation

Product description

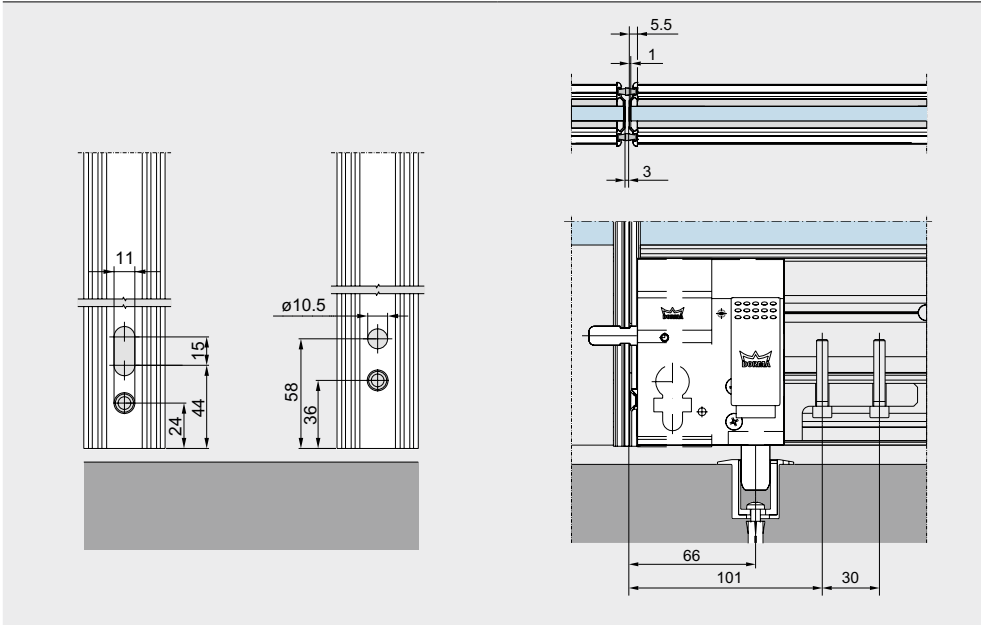

Profile machining
for end-mounted and face-mounted slide bolts performed by dormakaba

Preparation and mounting of vertical sealing profile for end-mounted slide bolt

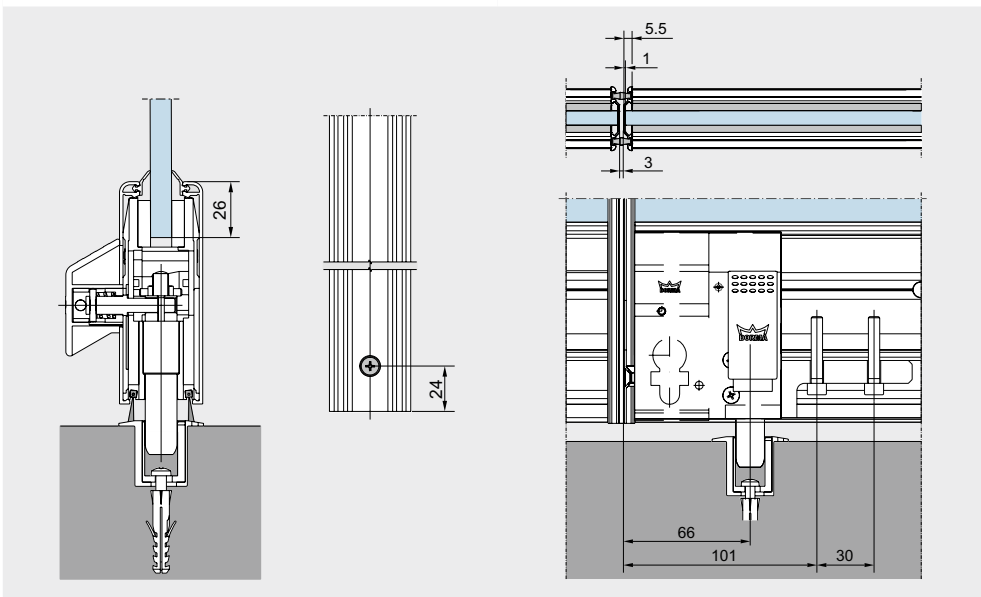

Preparation and mounting of vertical sealing profile for face-mounted slide bolt

Product description

Art. No.

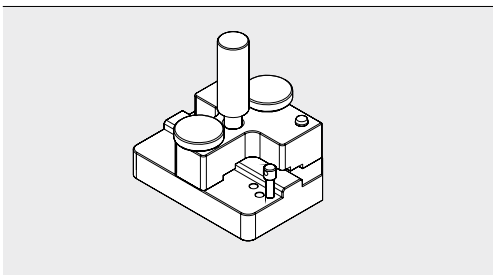

Tool for preparing the top of the vertical sealing profiles on site

8.40.070.000.99

Vertical sealing profiles – panel types

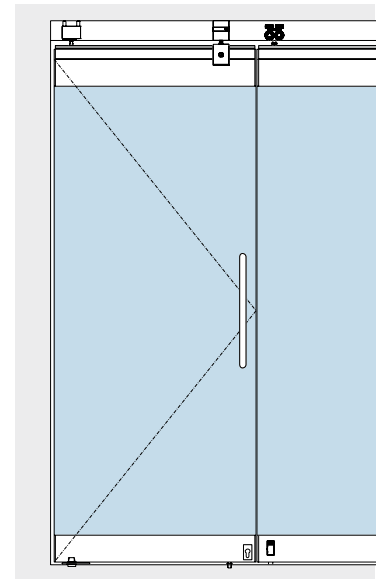
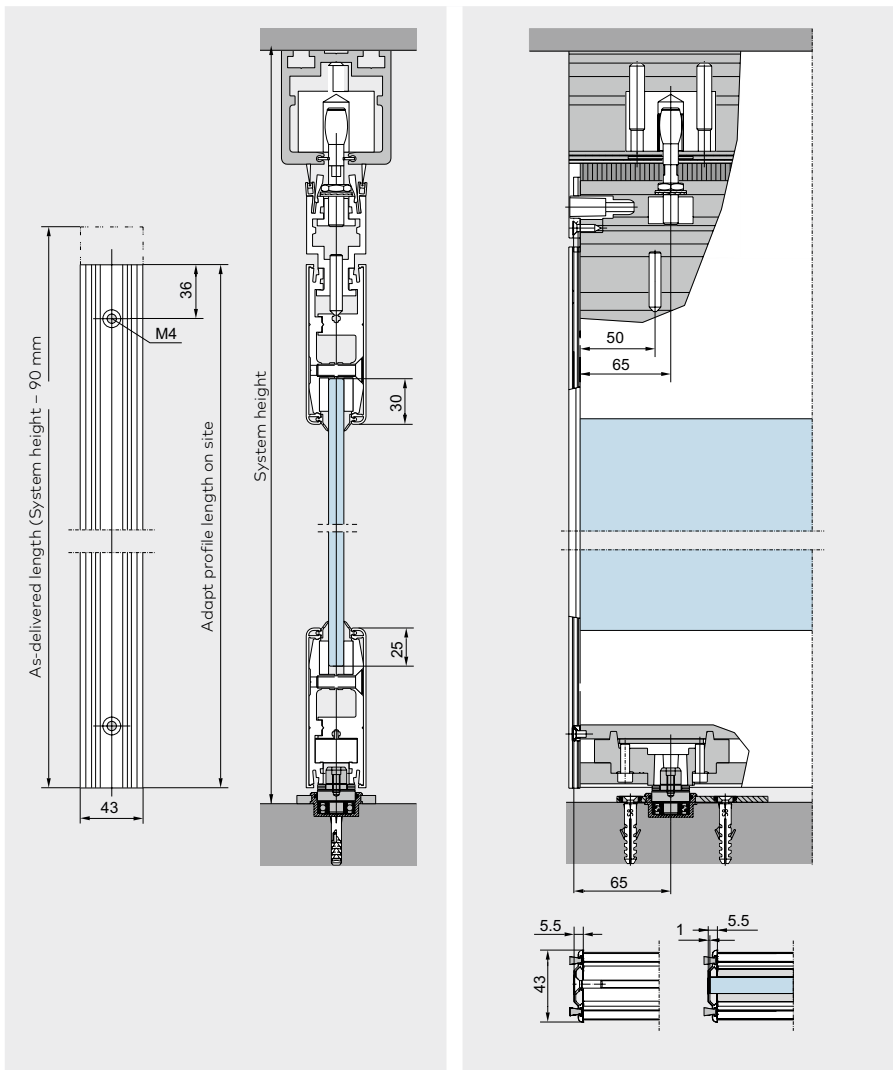

Single-End-/Double-Action Panels

As-delivered condition of the vertical sealing profiles:

Cut lengths supplied from factory
= System height – 90 mm

Holes and recesses are pre-machined in the profile for the bottom door rail only. Any further machining work required for connection to the top door rail has to be performed on site.

Installation instructions

When fitting the top and bottom door rails please ensure that the protrusion of the glass width on either side of a door rail is even. In case the panels incorporate a carrier profile a proper section of the double brush sealing profile is fixed to the carrier profile by a fixing cartridge. Prior to machining the sealing profile at the top for the exact length from the bottom to the top door rail, first hang the panels from the track rail and align. After the installation the vertical seal profiles need to be fixed with permanently elastic glue.

Vertical sealing profiles – panel types

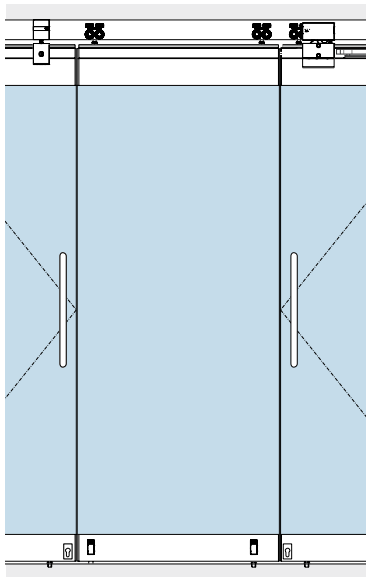

Sliding panels

As-delivered condition of the vertical sealing profiles:

Cut lengths supplied from factory
= System height – 90 mm

Holes and recesses are pre-machined in the profile for the bottom door rail only. Any further machining work required for connection to the top door rail has to be performed on site.

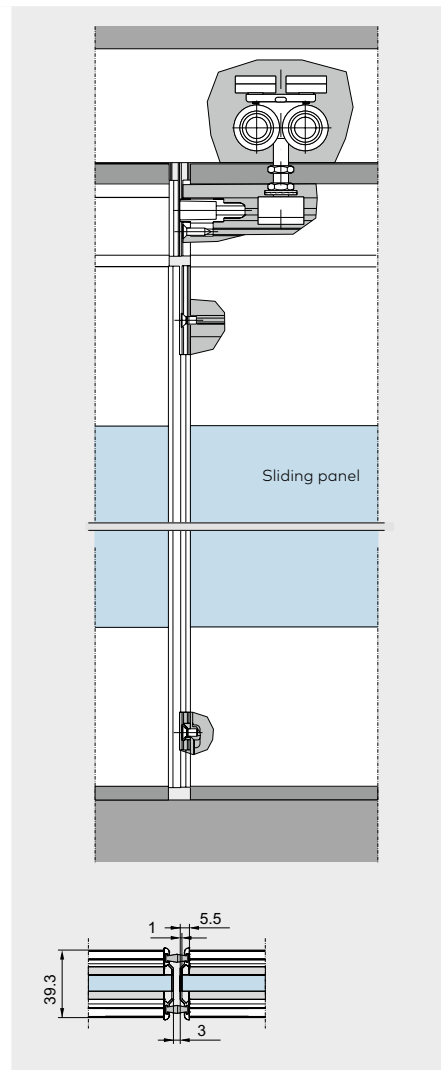
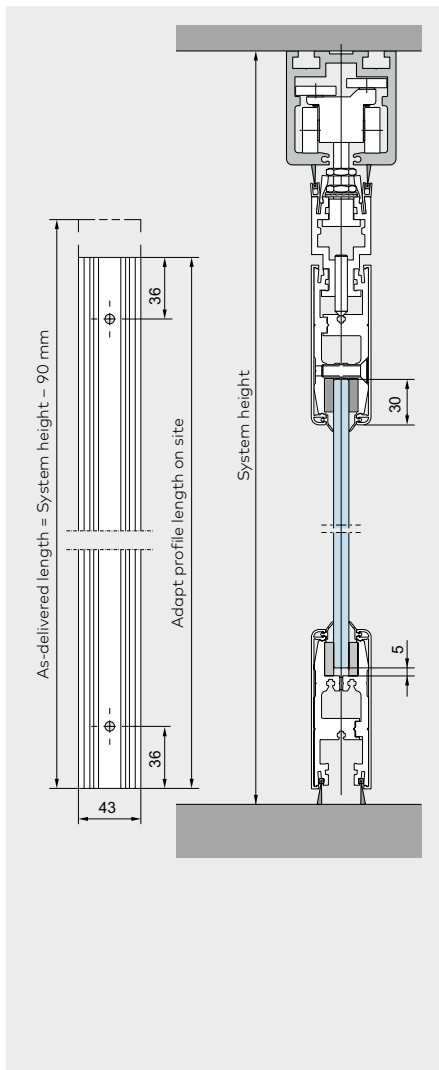

Installation instructions

When fitting the top and bottom door rails please ensure that the protrusion of the glass width on either side of a door rail is even. In case the panels incorporate a carrier profile a proper section of the double brush sealing profile is fixed to the carrier profile by a fixing cartridge. Prior to machining the sealing profile at the top for the exact length from the bottom to the top door rail, first hang the panels from the track rail and align.

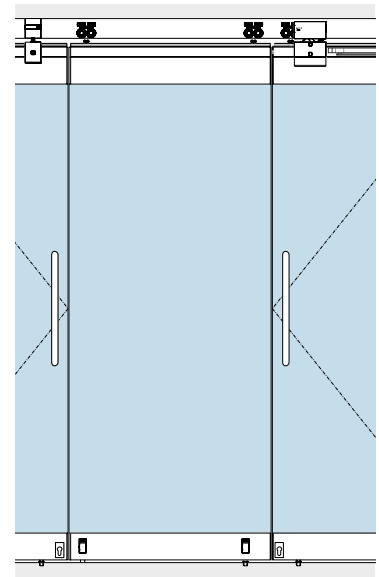
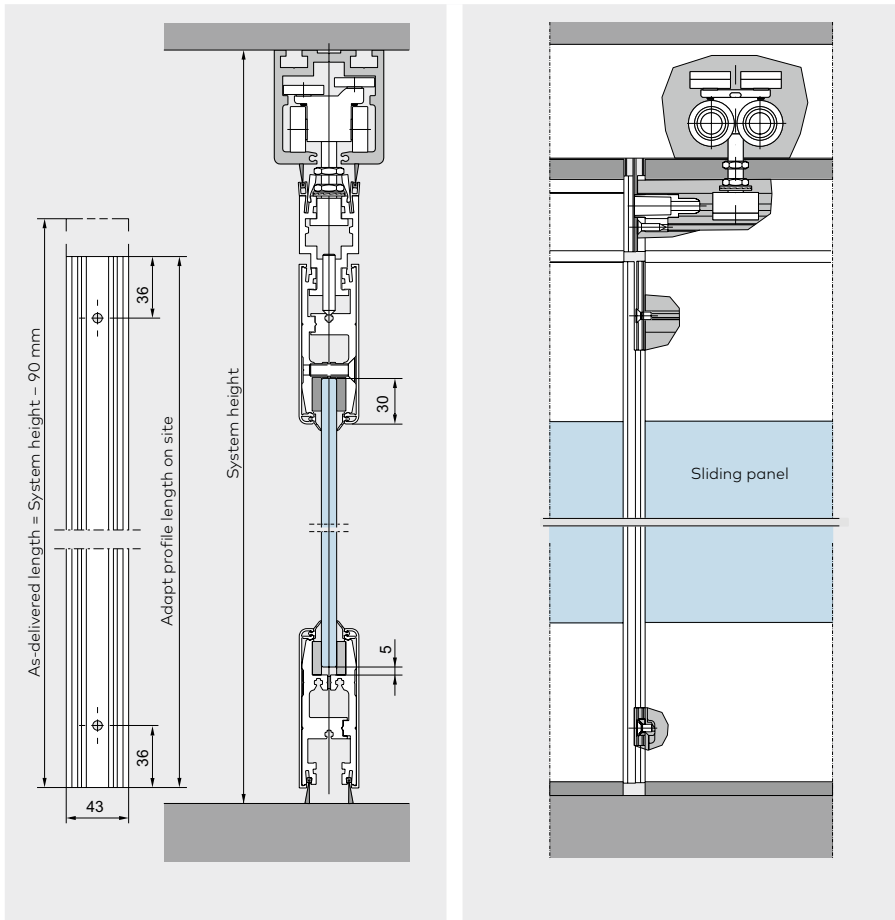

Sliding panels in segmented configurations

As-delivered condition of the vertical sealing profiles:
 Cut lengths supplied from factory
 = System height – 90 mm.

Holes and recesses are pre-machined in the profile for the bottom door rail only. Any further machining work required for connection to the top door rail has to be performed on site.

Installation instructions

When fitting the top and bottom door rails please ensure that the protrusion of the glass width on either side of a door rail is even. In case the panels incorporate a carrier profile a proper section of the double brush sealing profile is fixed to the carrier profile by a fixing cartridge. Prior to machining the sealing profile at the top for the exact length from the bottom to the top door rail, first hang the panels from the track rail and align.

Sealing profiles with the standard short type brushes in both brush channels.

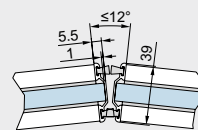

Sealing profiles with short type brushes in the inner brush channels and long type brushes in the outer brush channels.

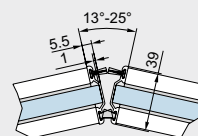

Sealing profile without brushes at the panel's free edge; sealing profile with short type brushes at the 90° adjoining panel.

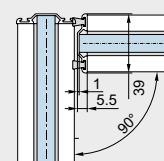

Vertical sealing profiles - panel types

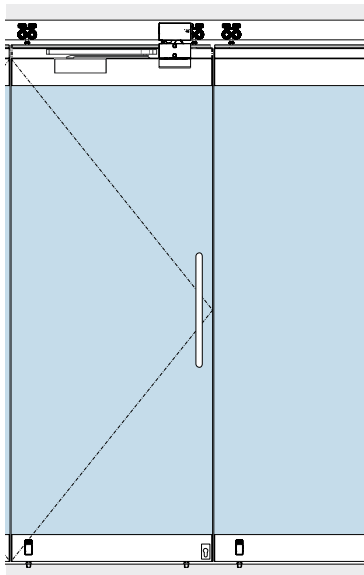

Single-action sliding panels (with TS 92 or ITS 96)/ double-action sliding panels (with ITS 96)

As-delivered condition of the vertical sealing profiles:

Cut lengths supplied from factory = System height – 90 mm.

Holes and recesses are pre-machined in the profile for the bottom door rail only. Any further machining work required for connection to the top door rail has to be performed on site.

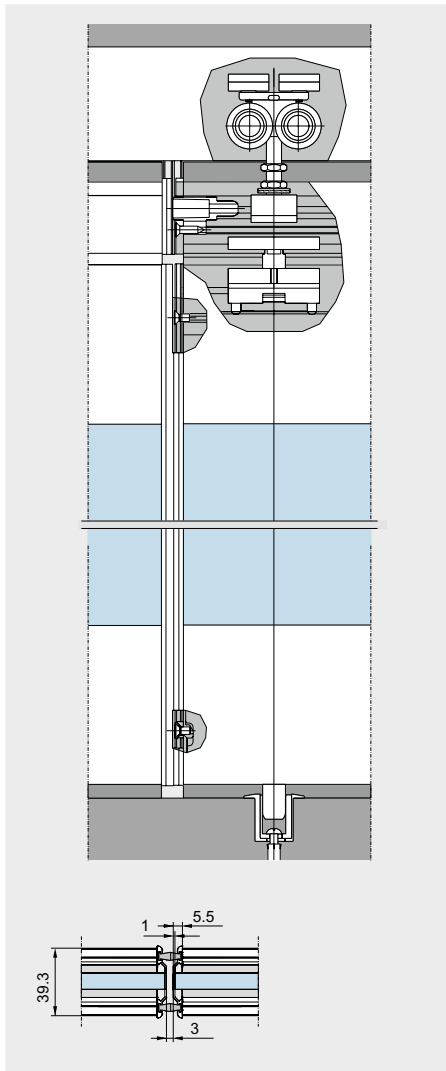
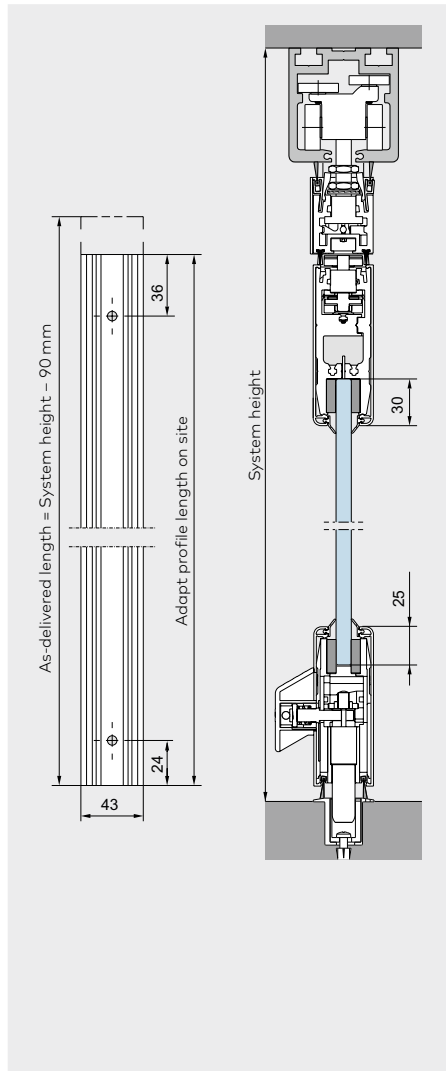

Installation instructions

When fitting the top and bottom door rails please ensure that the protrusion of the glass width on either side of a door rail is even. In case the panels incorporate a carrier profile a proper section of the double brush sealing profile is fixed to the carrier profile by a fixing cartridge. Prior to machining the sealing profile at the top for the exact length from the bottom to the top door rail, first hang the panels from the track rail and align.

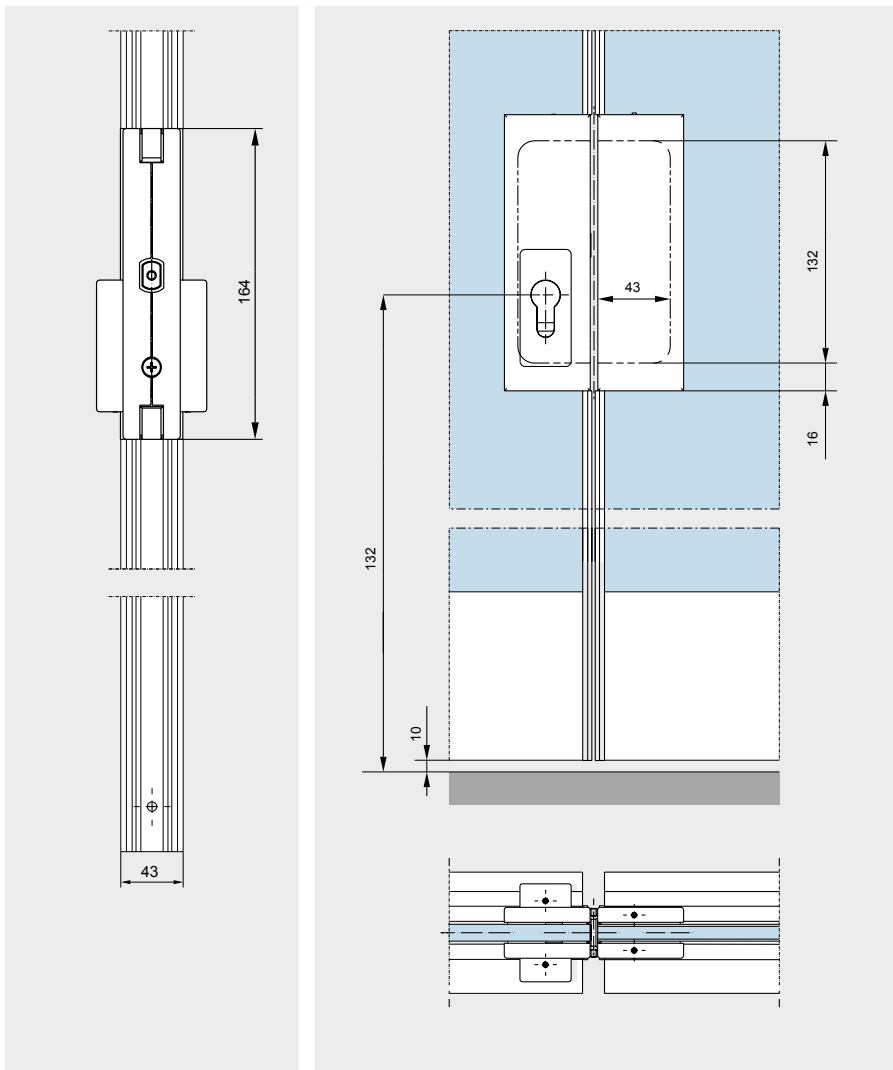

Installation instructions

When fitting the top and bottom door rails please ensure that the protrusion of the glass width on either side of a door rail is even. In case the panels incorporate a carrier profile a proper section of the double brush sealing profile is fixed to the carrier profile by a fixing cartridge. Prior to machining the sealing profile at the top for the exact length from the bottom to the top door rail, first hang the panels from the track rail and align.

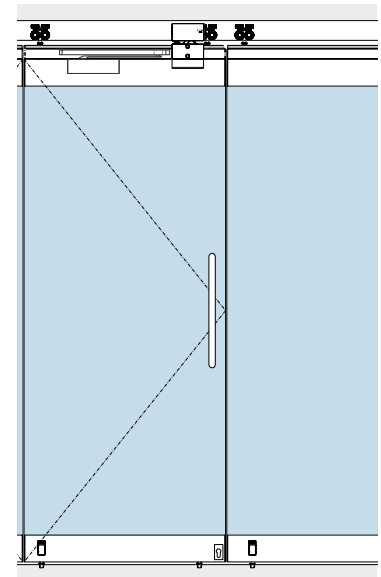

Single-action sliding panels (with TS 92 or ITS 96)/double-action sliding panels (with ITS 96) with UNIVERSAL centre lock and UNIVERSAL strike box

As-delivered condition of the vertical sealing profiles:

Cut lengths supplied from factory
= System height – 90 mm

Holes and recesses are pre-machined in the profile for the bottom door rail only. Any further machining work required for connection to the top door rail has to be performed on site.

Vertical sealing profiles – panel types

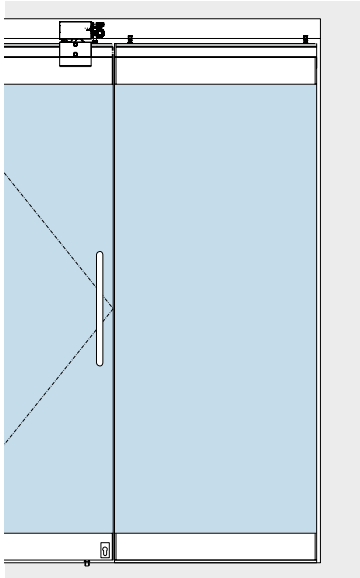

Fixed panels

As-delivered condition of the vertical sealing profiles:

Cut lengths supplied from factory = System height – 90 mm.

Holes and recesses are pre-machined in the profile for the bottom door rail only. Any further machining work required for connection to the top door rail has to be performed on site.

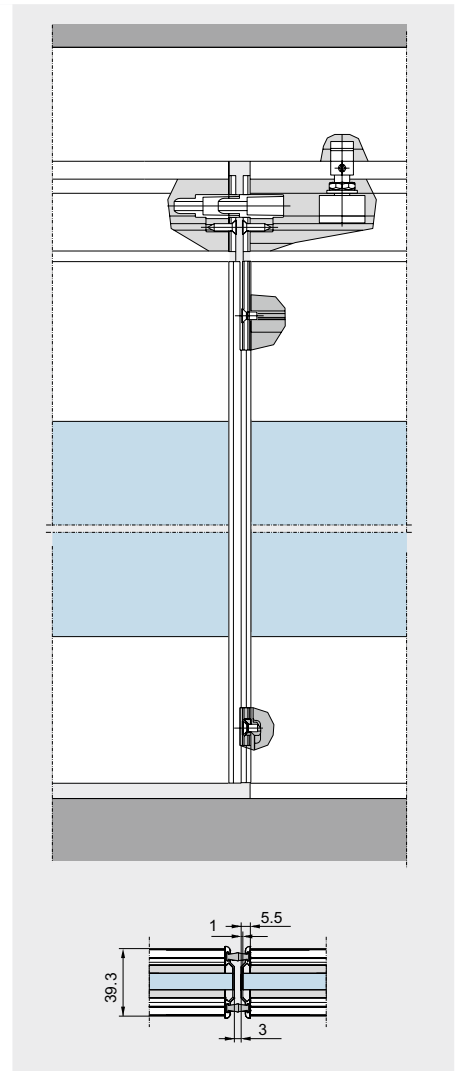
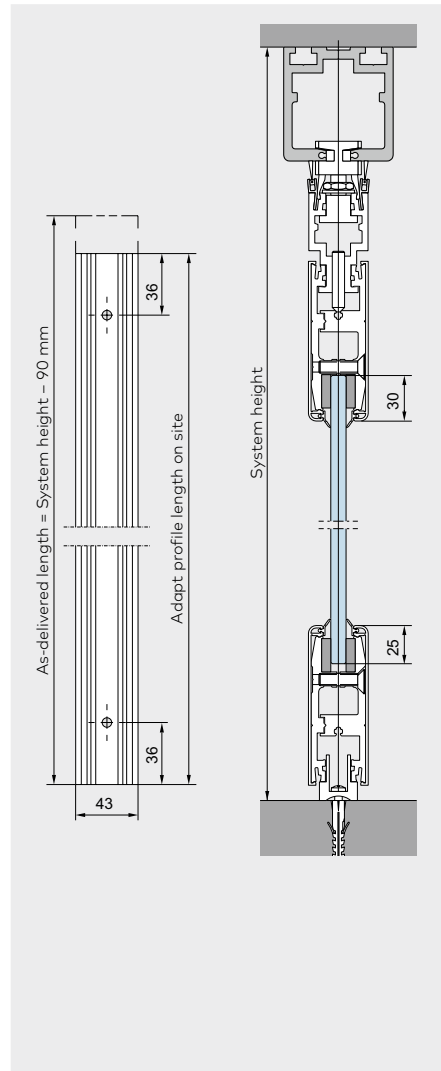

Installation instructions

When fitting the top and bottom door rails please ensure that the protrusion of the glass width on either side of a door rail is even. In case the panels incorporate a carrier profile a proper section of the double brush sealing profile is fixed to the carrier profile by a fixing cartridge. Prior to machining the sealing profile at the top for the exact length from the bottom to the top door rail, first hang the panels from the track rail and align.

Space for your notes

Pull handles, door knobs and recessed pull grip

The pull handle/knob system is designed for glass of 8, 10 and 12 mm thickness.

The pull handles can be fixed to both sliding and pivoting (swing) doors on one face using the appropriate connectors or on both faces by through-bolting (back-to-back arrangement).

Due to a flat structure recessed pull grips are also suitable for sliding doors.

The single-point fixings and through bolts are included as standard equipment in the scope of supply.

The pull handles can be fitted horizontally, vertically or in a handrail arrangement.

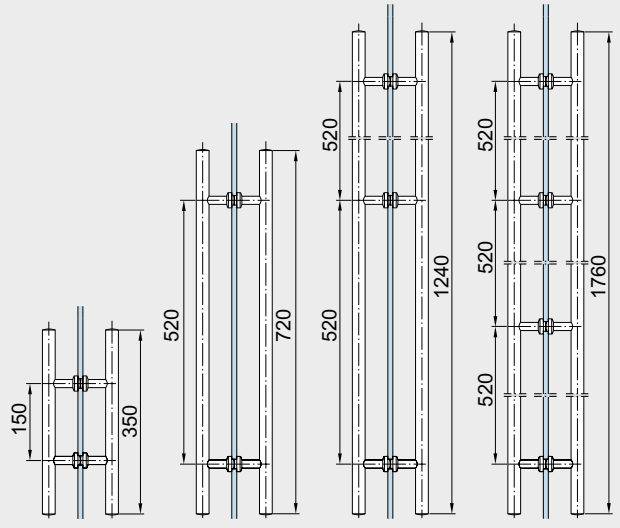
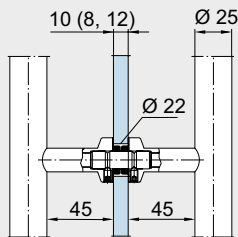
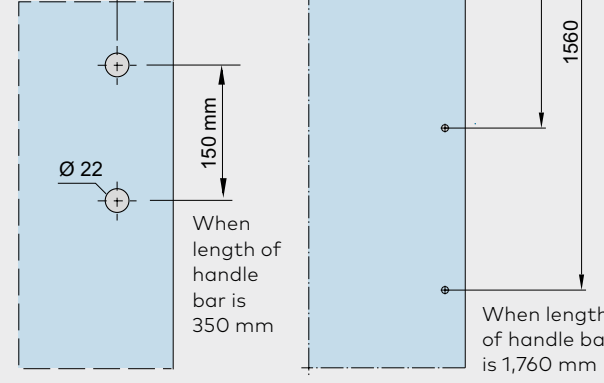

	Product description	Glass thickness	Art. No.
	<p>Pair of handle bars satin stainless steel length 350 mm, 2 fixing points, weight in kg: 1.254 material 1.4305 do., material 1.4404</p>	8/10/12 mm	21.267* 21.247
	<p>Pair of handle bars aluminum length 350 mm, 2 fixing points, weight in kg: 1.326 aluminum</p>	8/10/12 mm	03.400
	<p>Pair of handle bars satin stainless steel length 720 mm, 2 fixing points, weight in kg: 1.947 material 1.4305 do., material 1.4404</p>	8/10/12 mm	21.270* 21.250
	<p>Pair of handle bars aluminum length 720 mm, 2 fixing points, weight in kg: 2.423 aluminum</p>	8/10/12 mm	03.402
	<p>Pair of handle bars satin stainless steel length 1,240 mm, 3 fixing points, weight in kg: 3.400 material 1.4305 do., material 1.4404</p>	8/10/12 mm	21.273* 21.253
	<p>Pair of handle bars satin stainless steel length 1,760 mm, 4 fixing points, weight in kg: 5.000 material 1.4305 do., material 1.4404</p>	8/10/12 mm	21.276* 21.256

* Conversion sets for back to back pull handles for timber doors resp. other glass thicknesses see unter "Spacing adjustment for pull handles and door knobs", page 99.

Pull handles single

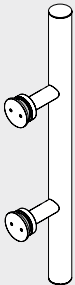
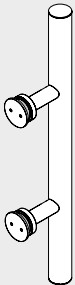
	Product description	Glass thickness	Art. No.
	Pull handles with single-point fixings, countersunk	8/10/12 mm	
	Edelstahl		
	Pull handle 350 mm with 2 fixings, material 1.4305 do., AISI 316L		29.268
	Pull handle 720 mm with 2 fixings, material 1.4305 do., AISI 316L		29.269
	Pull handle 1,240 mm with 3 fixings, material 1.4305 do., AISI 316L		29.271
	Pull handles with single-point fixings, clamping disc	8/10/12 mm	
	Pull handle 350 mm with 2 fixings, material 1.4305 do., AISI 316L		29.272
	Pull handle 720 mm with 2 fixings, material 1.4305 do., AISI 316L		29.274
	Pull handle 1,240 mm with 3 fixings, material 1.4305 do., AISI 316L		29.275
	Pull handle 1,760 mm with 4 fixings, material 1.4305 do., AISI 316L		29.277
			29.278
	Pull handles with single-point fixings, clamping disc	8/10/12 mm	
	Pull handle 350 mm with 2 fixings, material 1.4305 do., AISI 316L		21.240
	Pull handle 720 mm with 2 fixings, material 1.4305 do., AISI 316L		21.241
	Pull handle 1,240 mm with 3 fixings, material 1.4305 do., AISI 316L		21.281
	Pull handle 1,760 mm with 4 fixings, material 1.4305 do., AISI 316L		21.242
			21.283

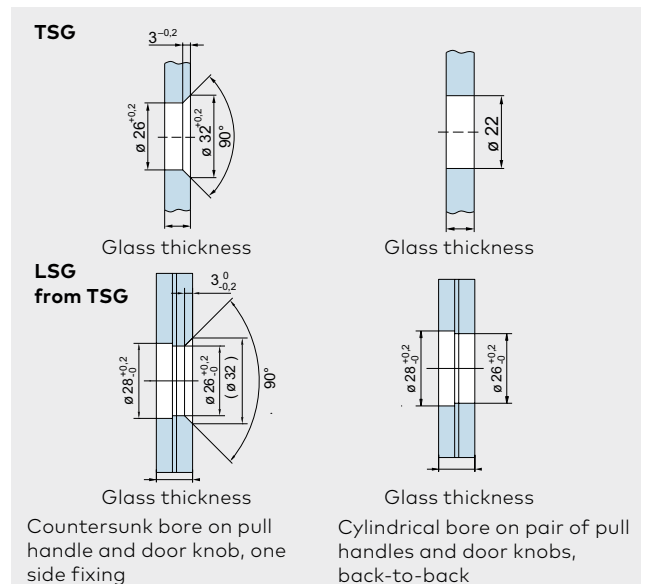
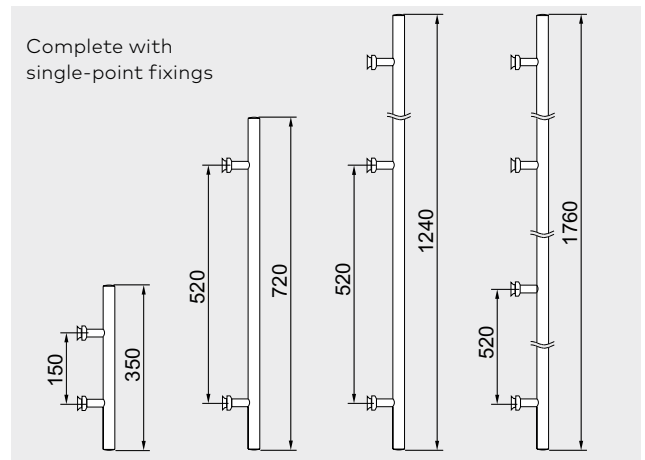
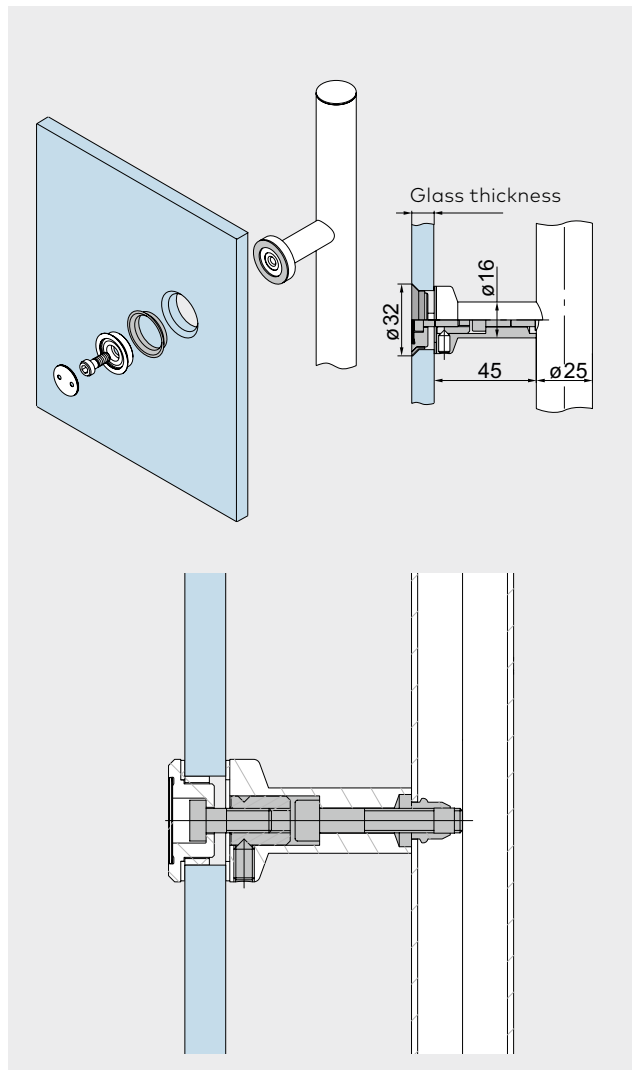

Spacing adjustment for pull handles and door knobs

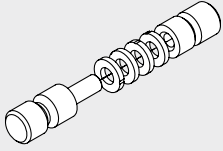
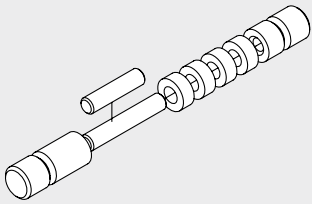
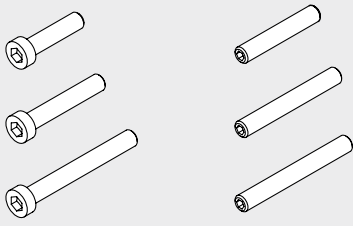
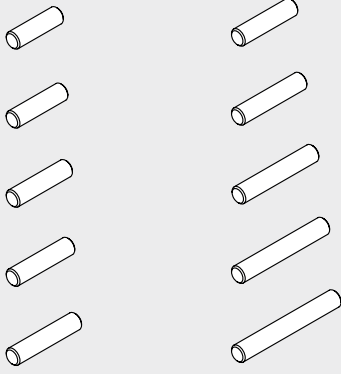
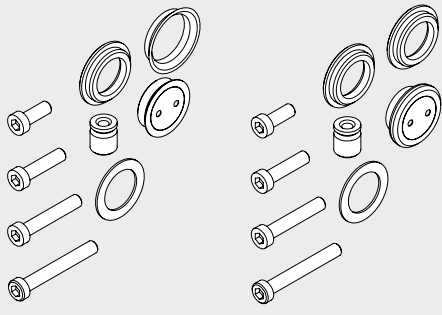
	Product description	Door thickness	Art. No.
 <p>Distance washer 2 mm</p>	<p>Conversion set 1 for glass doors, pair of pull handles / knob back-to-back</p> <p>without distance washer with 1 distance washer with 2 distance washers with 3 distance washers with 4 distance washers</p>	<p>13.5 – 21.5 mm</p> <p>13.5 mm 15 mm 17.5 mm 19 mm 21.5 mm</p>	21.285
 <p>Distance washer 5 mm</p>	<p>Conversion set 2 for timber doors, pair of pull handles / knob back-to-back</p> <p>without distance washer with 1 distance washer with 2 distance washers with 3 distance washers with 4 distance washers</p>	<p>20 – 40 mm</p> <p>20 mm 25 mm 30 mm 35 mm 40 mm</p>	21.286
 <p>Set 3 Set 4</p>	<p>Conversion set 3 for glass / timber doors*, pair of pull handles / knob back-to-back, countersunk 15 - 40 mm glass / timber thickness</p>		21.287
	<p>Conversion set 4 for glass / timber doors*, pair of pull handles / knob back-to-back, clamping disc 15 - 40 mm glass / timber thickness</p>		21.288
 <p>Set 5 Set 6</p>	<p>Conversion set 5 for glass doors*, recessed pull grip 13.5 - 21.5 mm glass thickness</p>		21.295
	<p>Conversion set 6 for timber doors*, recessed pull grip 20 - 40 mm timber thickness</p>		21.296
 <p>Set 7 Set 8</p>	<p>Conversion set 7 for glass / timber doors*, for pull handles fixed on both sides to pull handle fixed on one side, countersunk 8 - 40 mm glass / timber thickness 1 set per pull handle fixing</p>		21.297
	<p>Conversion set 8 for glass / timber doors*, for pull handles fixed on both sides to pull handle fixed on one side, clamping disc 8 - 40 mm glass / timber thickness 1 set per pull handle fixing</p>		21.298

*Not suitable for Arcos pull handles 26.500 / 26.510

Pair of pull handles

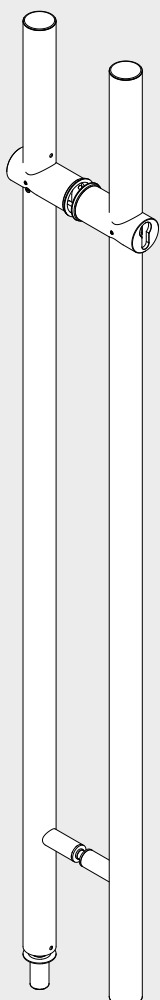
	Product description	Glass thickness	Art. No.
	<p>Pair of stainless steel handlebars, lockable on both sides, prepared for standard PZ, length 1200 mm, incl. floor socket</p>	<p>8 – 12 mm</p>	<p>21.580</p>
	<p>Pair of stainless steel handlebars, lockable on one side, prepared for standard PZ, length 1200 mm, incl. floor socket</p>	<p>8 – 12 mm</p>	<p>21.581</p>

Arcos pull handle

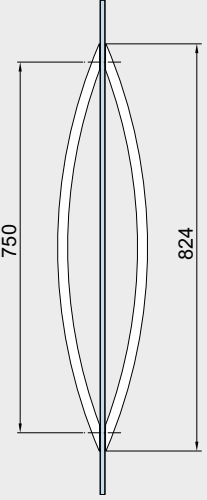
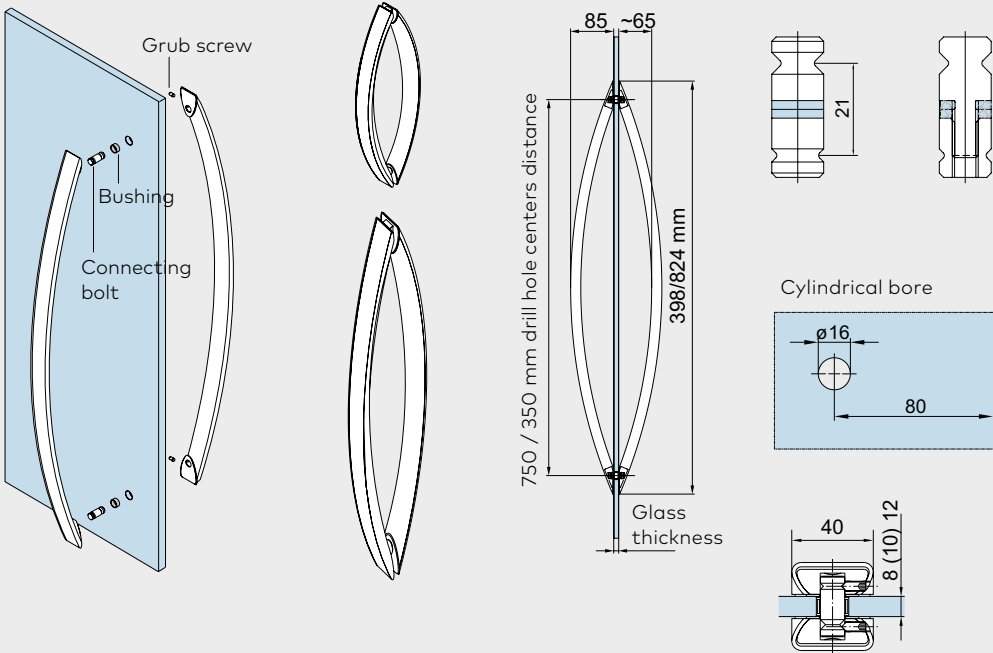
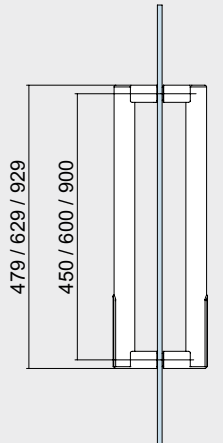
	Product description	Glass thickness	Art. No.
	<p>Arcos pair of pull handle incl. connecting bolt Aluminium, stainless steel look</p> <p>Pull handle 350 mm with 2 fixings Pull handle 750 mm with 2 fixings</p>	<p>8/10/12 mm</p>	<p>26.500 26.510</p>
			
	<p>BEYOND pull handle Glas thickness 10 / 12 mm with 2 fixing points (through bore diameter 22 mm)</p> <p>Length 450 mm Length 600 mm Length 900 mm</p>		<p>30.300 30.305 30.310</p>

Handle bars

Product description

Art. No.

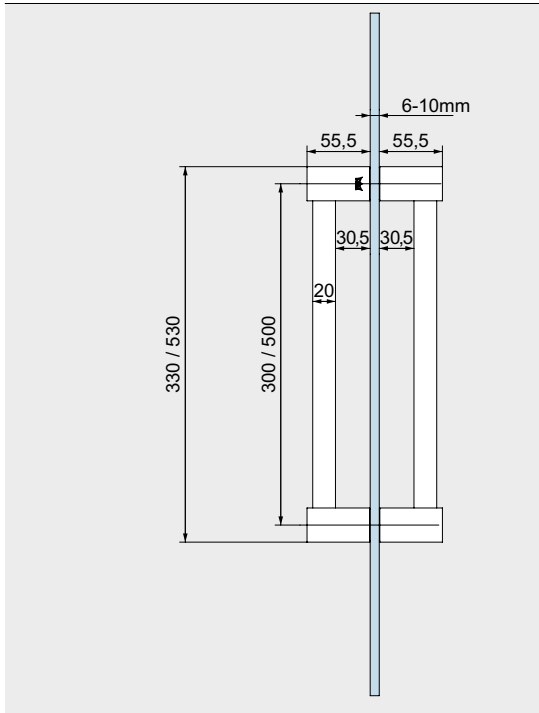

Pull handle "Quadrat"
 Glas thickness 6 - 10 mm
 with 2 fixings

Length 300 mm
 Length 500 mm

75.084
75.085

Recessed pull grips and door knobs

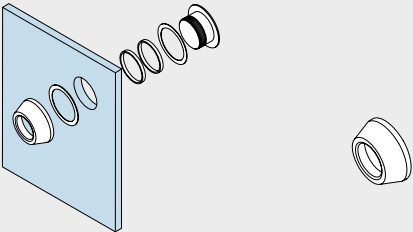
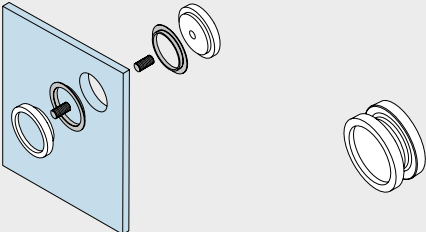
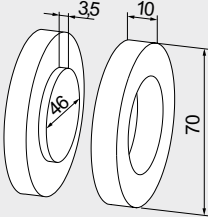
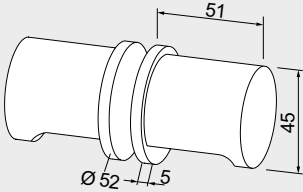
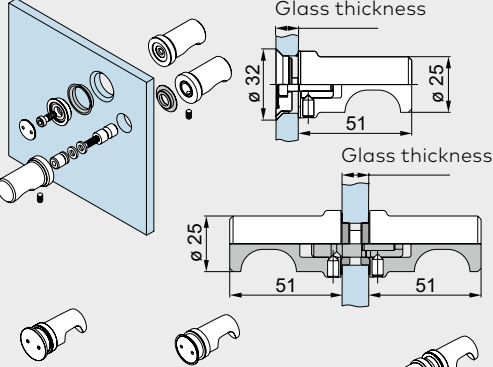
	Product description	Glass thickness	Art. No.
 <p>Ø 38 mm Glass bore</p>	<p>Recessed pull grip Ø 50 mm</p>	8/10/12 mm	21.290
 <p>Ø 50 mm Glass bore</p>	<p>Recessed pull grip Ø 60 mm</p> <p>Recessed pull grip with grip hole Ø 60 mm</p>	8/10/12 mm 8 mm 10 mm 12 mm	21.291 21.292 21.293 21.294
 <p>Ø 50 mm Glass bore</p>	<p>Recessed pull grip aluminum to be glued onto the glass Weight in kg: 0.072</p>		07.200
 <p>Ø 20 mm Glass bore</p>	<p>Door knob, aluminum Weight in kg: 0.400</p>		07.201
 <p>Single-point fixing clamping disc (Ø 22 mm)</p> <p>(Glass preparation please see under "pull handles single", page 98)</p>	<p>Door knob one side fixing</p> <p>Door knob with single-point fixing, countersunk Door knob with single-point fixings, clamping disc</p> <p>Door knob back-to-back</p>	8/10/12 mm 8/10/12 mm	21.422 21.426 21.423

Content

General Information

- 106 **Measuring up**
- 107 **General information**
- 109 **Safety-related information**



General Information

Measuring up

Important site measurements

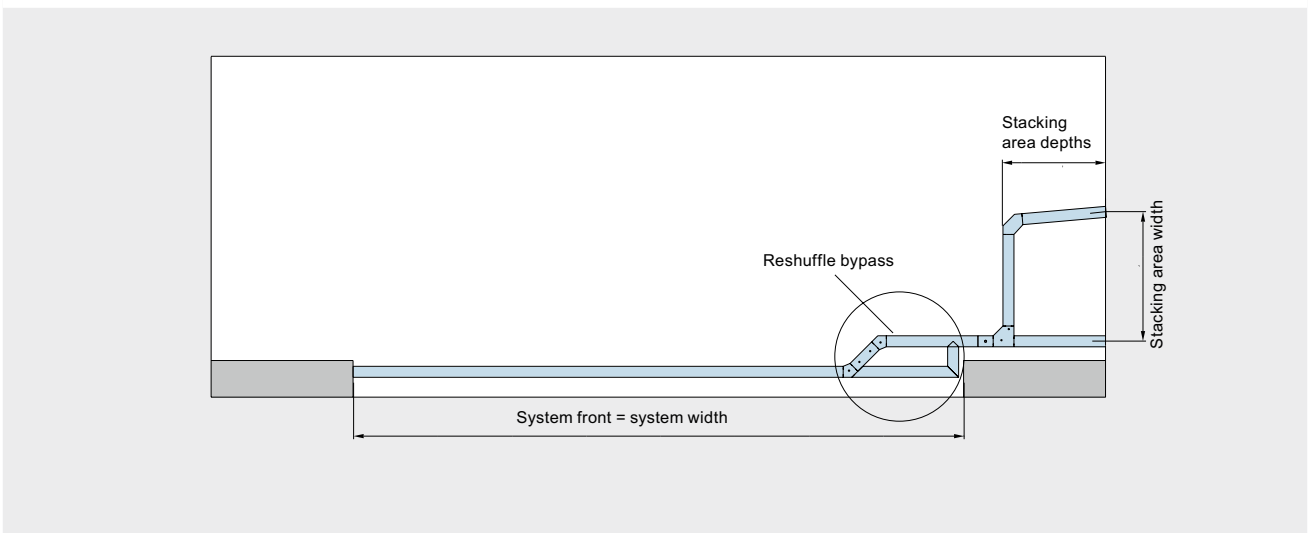
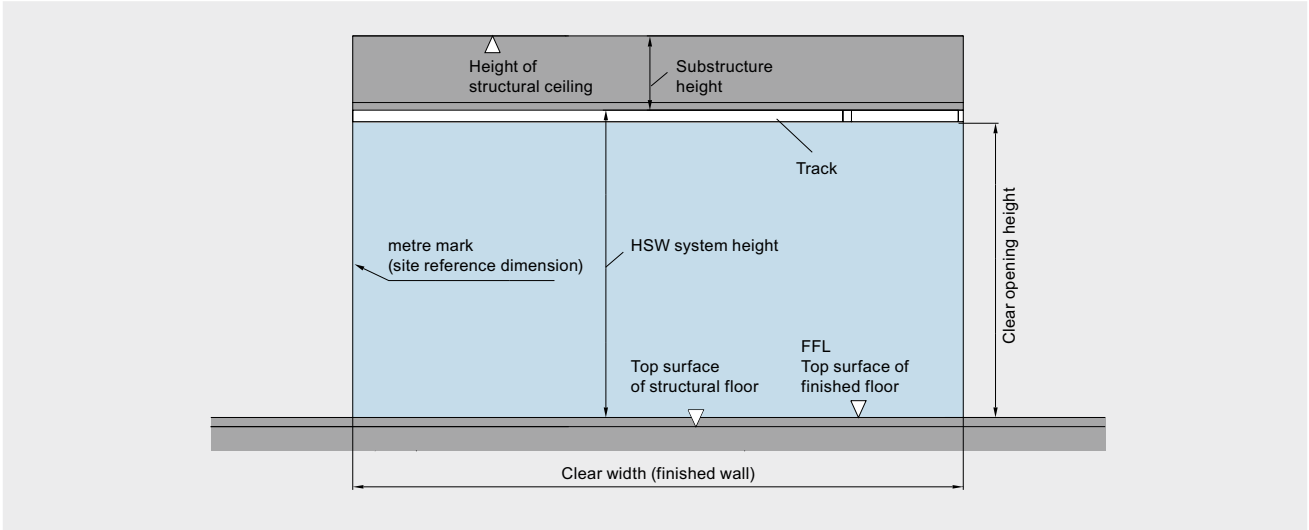

Notes on portal systems

Maintenance recommendation for high-frequency HSW systems

Horizontal sliding walls with glass panels have been developed in order to provide retail outlets with generous and enticing frontages – entrances that offer easy accessibility and an inviting appearance for customers. When the frontages are closed, they can double up as expansive shop windows.

In cases where double-action sliding panels are used for main entrances as a portal system (i. e. in shopping malls or as similar operated HSW systems) they are submitted to very high daily traffic volumes and usage frequency rates.

The door closers and pivot bearings used by dormakaba have been successfully tested in accordance with the requirements of EN 1154. EN 1154 specifies 500,000 test cycles for manually operated closing devices.

High-frequency portal systems such as the above can reach this number of cycles after just a few months. Consequently, dormakaba recommends that such units be regularly maintained. The higher the usage levels, the more frequently the equipment should be serviced by either the installation firm or a similarly specialized fitter.

In addition to any door closer that may be fitted, a suitable opening limitre (to be provided on site) will also be required as protection for single-action and double-action sliding panels. In the case particularly of public and highly frequented entrance systems, door closers are unsuitable as opening limitres as any excess pressure applied to doors will lead to high stress forces being applied at the sweep maximum.

Finishes

Deviations in colour due to production procedures cannot be totally excluded.

HSW systems with surface finishes 700 and 701 contain different component materials.

In the case of FSW (folding sliding walls) systems, for example, the folding hinges are always of aluminium, while the standard surface finish for brush profiles and end covers is black anodised (E6/C35). These various components can also optionally be anodised or powder-

coated so that they resemble the ordered surface finish. The standard surface of upper locking units and upper locking bolts is a powder-coated RAL colour.

Typical manufacturing flow marks appear when anodising the milled area of the track rail modules. As an alternative to the anodized EV 1 surface finish, we therefore offer modules and track rails in all lengths in a powder-coated version similar to EV 1 for visual reasons.

Finishes			
Aluminium	dormakaba No.	Sim. to Eloxal I	Sim. to Eloxal II
AL mill finish (Aluminium R 600)	100		
AL silver EV1 anodized (similar Eloxal I EV1 / Eloxal II C 0)	101	EV1	C 0
AL similar satin stainless steel anodized	107		
AL similar satin stainless steel anodized (for profile material) (similar Eloxal II C 31)	113		C 31
AL special color anodized	199		
Powder coated colours	dormakaba No.	Sim. to HEWI-No.	Sim. to RAL
AL traffic white powder coated	300	99	9016
AL special color powder coated (Standard powder according to RAL)	399		
Special colour	dormakaba No.		
Satin stainless steel (Niro S 700 ST)	700		

Finishes HSW EASY Safe	
Aluminium	dormakaba No.
AL mill finish (Aluminium R 600)	100
AL silver anodized (Silver N 600 ST) (compatible with finish 114)	150
AL niro anodized (Niro N 700)	157
AL special color anodized	199
Coloured coatings	dormakaba No.
AL black powder coated (Black P 190 SG)	304
AL similar EV1 powder coated (Silver P 600 SG)	318
AL white powder coated (White P 100 SG)	350
AL high weather resistant powder coated (Color P WR)	398
AL special color powder coated (Standard powder according to RAL)	399

Safety-related information

Important safety-related information for the mounting and use of dormakaba glass fittings.

(Follow these instructions in addition to the mounting and operating instructions in order to avoid damage of product and damage to person or property.)

Important: All users have to be informed about relevant points mentioned in these safety-related information and the mounting and operating instructions!

Allgemein

1. dormakaba recommends using TSG-H (heat soaked toughened safety glass) to DIN EN 12150-1.
2. dormakaba glass fittings are not suitable for application in rooms where chemicals (e. g. chlorine) are used such as indoor swimming pools, saunas or salt-water pools.
3. Never move sliding panels faster than walking speed and always stop the door manually before it reaches end position.
4. Do not shut swing doors with excessive force. Install door stop to prevent door from opening too far.

Mounting

1. Only properly qualified and specially trained staff is authorised to mount dormakaba glass fittings.
2. Never use glass with conchoidal fractures and/or damaged edges.
3. Due to crushing hazards – among others in the area of the secondary closing edge – and possible injury caused by breakage of glass during mounting, corresponding protective clothing (especially gloves and protective goggles) is required.
4. Clean clamping area with fat solvent (standard commercial cleaning agent) before mounting the glass fitting.
5. Never use clamping shoes on structured glass surfaces (except on satined glass) or glass of heavily varying thickness unless with a corresponding levelling layer.
6. Never use clamping shoes on self-cleaning coatings.
7. When adjusting glass elements, always stick to the required clearance for the respective fitting. Adjust clearance so that the glass does not touch hard components such as glass, metal or concrete.
8. Make sure not to use excessive force when installing the glass (avoid local stress resulting from very tight screws).

Maintenance

Check fittings at regular intervals for proper positioning and smooth running and door for correct adjustment. Especially highly-frequented door systems require inspection by properly qualified staff (specialised companies or installation firms). Immediately replace damaged glass elements (no glass flaking and/or conchoidal fractures)!

General care instructions

The surface finishes of the fittings are not maintenance-free and should be cleaned according to their material and design.

- For metallic surfaces (anodised finishes, stainless steel) please use appropriate cleaning agents without abrasive additives only.
- For varnished surfaces please use appropriate solvent-free cleaning agents only.
- Brass surfaces (without surface protection) have to be treated with an appropriate maintenance agent on occasion, to avoid tarnishing.

For practical planning, please use our drawings dormakaba DETAIL.

The printed colours indicating the surface finishes are not 100% true, but do provide a useful guide.

Statements made with regard to the nature or use of the products are for the purposes of descriptions. Assent with regard to the existence of particular properties or particular uses always requires special written agreement. Pictures may show special designs which are different to the standard scope of delivery.

Subject to change without notice.

Space for your notes



www.glas-innovationen.com/en



**Door
Hardware**



**Electronic
Access & Data**



**Mechanical
Key Systems**



Lodging Systems



**Entrance
Systems**



**Interior Glass
Systems**



Safe Locks



Service

dormakaba
International Holding AG
Hofwissenstrasse 24
CH-8153 Rümlang
T +41 44 818 90 11
info@dormakaba.com
www.dormakaba.com