

NEW!

Automatically
convincing!

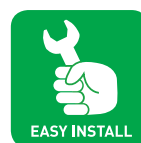

reddot design award
winner 2013

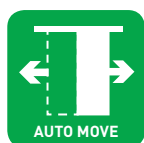

Portavant 80 automatic – automatically convincing



Portavant 80 automatic creates attractive design accents

Portavant 80 automatic has been honoured with the “red dot design award”.



reddot design award
winner 2013

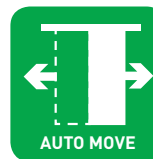

AUTO MOVE

The automatic function for your comfort:

Opens and closes the door automatically, silently and reliably – so you can keep your hands free for other things.



EASY INSTALL

The solution for easy installation without glass cutout:

Turns installing glass sliding doors into child's play through well-proven clamping and roller assembly technology.



SAFE USE

The intelligent control for your safety:

Reacts immediately if the door touches an obstacle during automatic closing or opening. The low kinetic energy mode means it easily meets all standard safety requirements.



MODE SELECT

The choice of the operating mode in line with your requirements:

Allows you to decide whether a motion sensor, push button, remote control or the Push & Go function should be the "open sesame" for your automatic door and which door function is triggered by the pulse.



PLUG & GO

The solution for electrical connection and configuration without specialist knowledge:

Facilitates the electrical connection in just three plug-in steps while the display guides you through the configuration.



SYSTEM FIT

The modular solution for your installation project:

Offers solutions for almost any installation project with modular system components which can be combined in a variety of ways.

Portavant 80 automatic sets the course in product design



reddot design award winner 2013

Portavant 80 automatic has been honoured with the “red dot design award”. This coveted and internationally recognised prize is only awarded to products which are clearly set apart from comparable products through their exceptional design.

The decision is based on assessment criteria including

- degree of innovation,
- functionality,
- formal quality,
- ergonomics,

- durability,
- emotional content,
- product periphery,
- self-explanatory quality and
- ecological compatibility.

As one of 4662 entries from 54 nations, Portavant 80 automatic proved convincing for the red dot jury consisting of 37 design luminaries from 24 countries. It will undoubtedly convince you too!

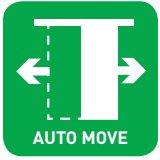

AUTO MOVE

The automatic function for your comfort

Be it a private residence, the office, a lawyer's office or a doctor's surgery, a hotel or restaurant:

AUTO MOVE

- Opens the door automatically so that you can keep your hands free for other things.
- Closes the door automatically and smoothly, ensuring discretion and wellbeing in gently closed spaces offering comfort, silence, pleasant warmth and all the privacy you need.

- Is convincingly quiet (less than 55 dB). It barely makes any more noise than a manual sliding door.*
- Can be manually operated whenever necessary – e.g. in the event of a power cut. Here Portavant 80 automatic proves compelling with very low slide resistance, setting new standards for belt-driven automatic doors.

AUTO MOVE doesn't just move doors, it also moves the spirit!



* Measured in a laboratory setting. Noise is dependent on the type of door and composition of the wall or ceiling.



SAFE USE

The intelligent control for your safety

SAFE USE ensures that the door reacts instantly to any obstacles in its path as it opens or shuts by stopping immediately and returning directly to its starting point, where it remains until the hold-open period has expired or there is another pulse.

If the door is started again and touches an obstacle in the same place for a second time, the intelligent control system recognises the multiple touch and temporarily disables the door. The number of times that an obstacle is touched is therefore kept to a minimum. Once the obstacle has been removed, the door can be activated again with a push.

The combination of an intelligent control system with a low kinetic energy mode (limited sash

weights and rates of motion) ensures a high level of personal protection so that automatic sliding doors can, as a rule, also be operated without safety edge monitoring sensors in accordance with DIN 18650 and EN 16005, respectively.

If people requiring special protection (e.g. small children) are likely to get in the way of the door, it's easy to switch the door to semi-automatic mode (the door only moves on deliberate activation and under supervision of the activating user) or manual mode. It is also possible to reduce the speed of travel (especially when closing).

Compliance with all standards and guidelines applying to automatic doors with low kinetic energy mode and the Portavant 80 automatic safety concept was confirmed by TÜV through type testing.

SAFE USE creates a save environment for everything you value.







MODE SELECT

The choice of the operating mode in line with your requirements

With **Portavant 80 automatic** you can select the operating mode in line with your requirements via the two-row display and a user-friendly menu:

In **automatic mode**, the door opens on being triggered with a pulse and closes again automatically after a set period, ensuring discretion and wellbeing in closed spaces offering comfort, silence, pleasant warmth and all the privacy you need. Possible pulsing devices can be motion sensors, push buttons, radio remote control and/or the Push & Go function. A double tap on the push button or radio remote control or manually stopping the door just after it has started to close can temporarily disable automatic closing – the door then remains open until automatic mode is activated again with another pulse. This can be useful in situations where there is temporarily increased traffic and in which constant closing would be a nuisance (e.g. a party). In automatic mode you can also choose whether installed motion sensors should be switched on or off to prevent pets, for example, entering a room.

In **semi-automatic mode**, the door only opens when the user triggers a pulse using the push

button, radio remote control or the Push & Go function. If motion sensors are installed, the latter remain switched off. In this mode, the door remains open until another pulse is triggered. This means that in semi-automatic mode the door only moves under the control of the activating user. Semi-automatic mode can be especially useful if there are people in the building requiring special protection (e.g. small children).

The automatic door can also be switched to **manual operation** at any time and used like any ordinary sliding door without activating the drive unit.

Hotels can choose locking modes which prevent guests changing the setting chosen by the hotel operator.

MODE SELECT allows you to decide the “open sesame” for your automatic door and which door function is triggered by the pulse.



The following pulsing devices are offered by Portavant 80 automatic:



Push & Go

With just a gently push of the door, the system immediately recognises the direction of motion and automatically continues in that direction. Push & Go can be used both to open and close the door.



Push button

Portavant 80 automatic can also be operated by means of a radio transmitter in combination with a wall push button, which you can choose from any range of flush-mounted push buttons. If a radio solution is to be used, a radio receiver can very easily be inserted into the control unit of the door using the Plug & Go function. Push buttons can, of course, also be connected by cable.



Radio remote control

If you wish to open and close the door at your convenience from a remote location (e.g. the sofa or from behind a desk), you can use a radio remote control. One remote control can operate up to four doors.



Motion sensor

Your Portavant 80 automatic door opens as if by magic with motion sensors. The high-end motion sensor from the Portavant range can even recognise the direction of movement and largely block out cross movement. This ensures that the door only opens if you walk towards it and not if you are moving away from it or are just walking past at a distance.

Standard function

Optional accessories



EASY INSTALL

The solution for easy installation without glass cutout

Portavant 80 automatic proves as compelling as the tried and tested Portavant 120 because it uses the same clamping and roller assembly technology and therefore offers straightforward and simple installation.

No glass cutout necessary

The well-proven clamping technology makes work on the glass unnecessary. The suspension system has been developed in such a way that the sashes are securely held by the clamp mechanism. The drive belt is also compactly accommodated in the track without needing a glass cutout.

Ease of assembly

Portavant impresses through its ease of assembly and simple handling in all installation situations:

- The sash can be hung on the mounted track from the front without difficulty. No need to hang the heavy sash into the cover profile!
- Anti-tilting devices and safety catches can be adjusted at a later time.

Easy positioning

Portavant 80 automatic glass sliding doors can be adjusted horizontally and in height with only a few actions (height adjustment ± 4 mm).

Simple installation of the drive technology

The drive unit is simply screwed sideways into the track. It can be used on either the right or left side. The drive belt too is easy to insert by threading it through the unit and attaching it with front access.

EASY INSTALL turns the installation of glass sliding doors into child's play.





PLUG & GO

The solution for electrical connection and configuration without specialist knowledge

Electrical connection

Thanks to an intelligent plug-in system, it is possible to connect Portavant 80 automatic to power in three easy steps without any specialist knowledge:

1. Plug in the display cable
2. Plug in the radio receiver or pulsing devices
3. Plug in the mains cable.

An electrician is only required in exceptional situations (e.g. to lay concealed wiring).



Configuring the door

A user-friendly menu guide and two-row display make configuring the door a piece of cake. A learning cycle is run automatically to find the stop positions.

With PLUG & GO, electrical connection and configuration are also a total breeze.



SYSTEM FIT

The modular solution for your installation project

Portavant 80 automatic is designed as a modular kit which makes use of system components of Portavant 120 and can be partly extended in combination with them.

Portavant 80 automatic adapts variably to the respective width of your door opening and can be installed with a track mounted to the ceiling (with or without sidelights), to the wall or in a glass façade. It's even possible with Portavant 80 automatic to implement two-sash systems with just one drive unit!

Portavant 80 automatic is suitable for on-wall and in-wall mounting.

Complete sets offer logistics and storage just as you need them, simplifying the ordering process and guaranteeing that the entire installation process can be done on site.

With its modular components, SYSTEM FIT makes any installation project possible.

The Portavant system can be used in many different installation situations:



Wall-mounted track one sash or two sashes

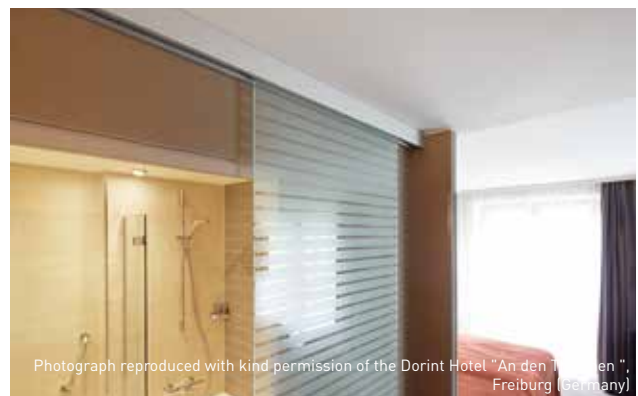

Ceiling-mounted track one sash or two sashes



Ceiling-mounted track with sidelight one sash or two sashes



Track mounted on glass façade one sash

Familiar Willach quality

For more than 120 years Willach has stood for supreme quality, excellence in processing as well as the long service life of its products. You will find Willach's familiar high quality also in the products of the Portavant 80 automatic range:

Supreme technical quality

- Extremely long service life (the TÜV type testing confirmed 500,000 sliding cycles)
- Minimum wear and tear thanks to a motor without sliding contacts, wire-reinforced toothed belt and precision steel ball bearings with high-performance plastic coating

Traditional delivery reliability

The standard product range is held in stock in the factory at Ruppichteroth (Germany) and delivered with Willach's familiar delivery reliability and dependability.

Competent advice

Competent advice and technical support for all questions are provided by technical office and field staff. With Portavant 80 automatic, too, you benefit from the company's traditionally high service quality.



Technical information

Door weight	Up to 80 kg for one-sash systems Up to 60 kg per sash for two-sash systems
Height-width ratio	The maximum height-width ratio of the sashes is 2.5:1.
Glass thickness for sliding door	
Tempered glass	8/10/12 mm
Laminated safety glass (made of tempered glass)	8.76/10.76/12.76 mm
Glass thickness for sidelights and glass façades	
Tempered glass	18/10/12 mm
Laminated safety glass	8.76/10.76/12.76 mm
Available profile lengths	2596 mm, 5196 mm* as well as fixed lengths
Execution	One sash or two sashes; for right and left hand use; wall mounting, ceiling mounting, ceiling mounting with sidelight, mounting on glass façade; also in-wall mounting; colours: natural aluminium (EV1) or stainless steel effect (C31) (main visible surfaces brushed)
Application parameters	0 – 40°C, IP 20 Planning guide: approx. 150-200 sliding cycles/day (max. 150 sliding cycles/hour)

* Divergent profile lengths for mounting on glass façade; please contact us.

Broad model range to meet customer requirements

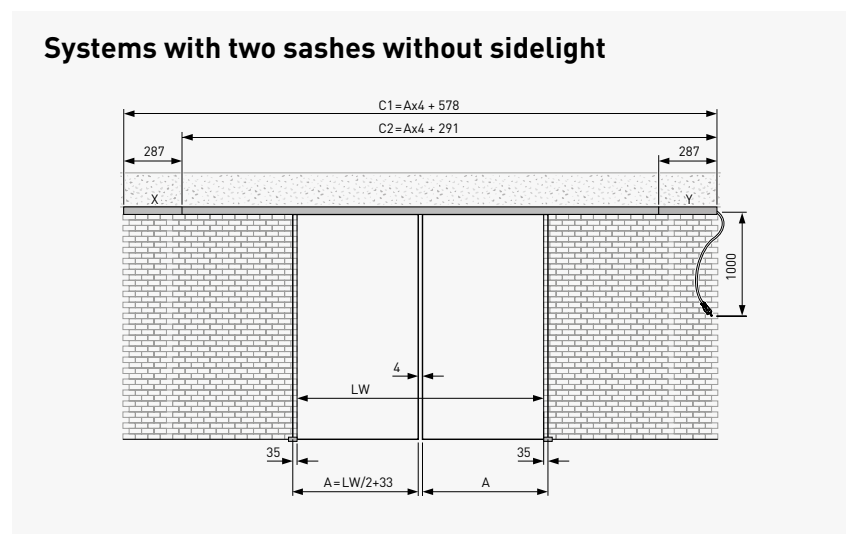
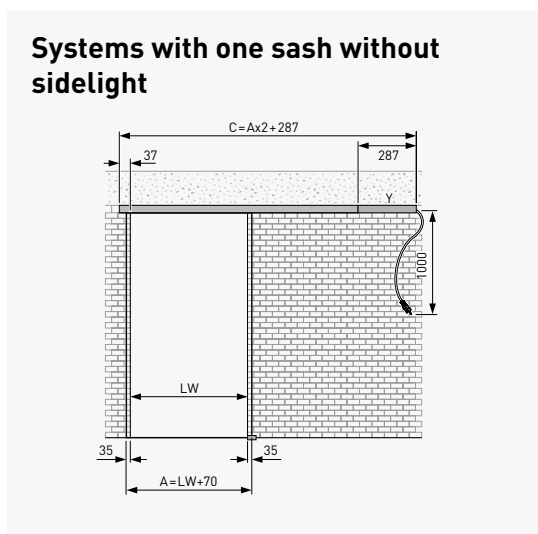
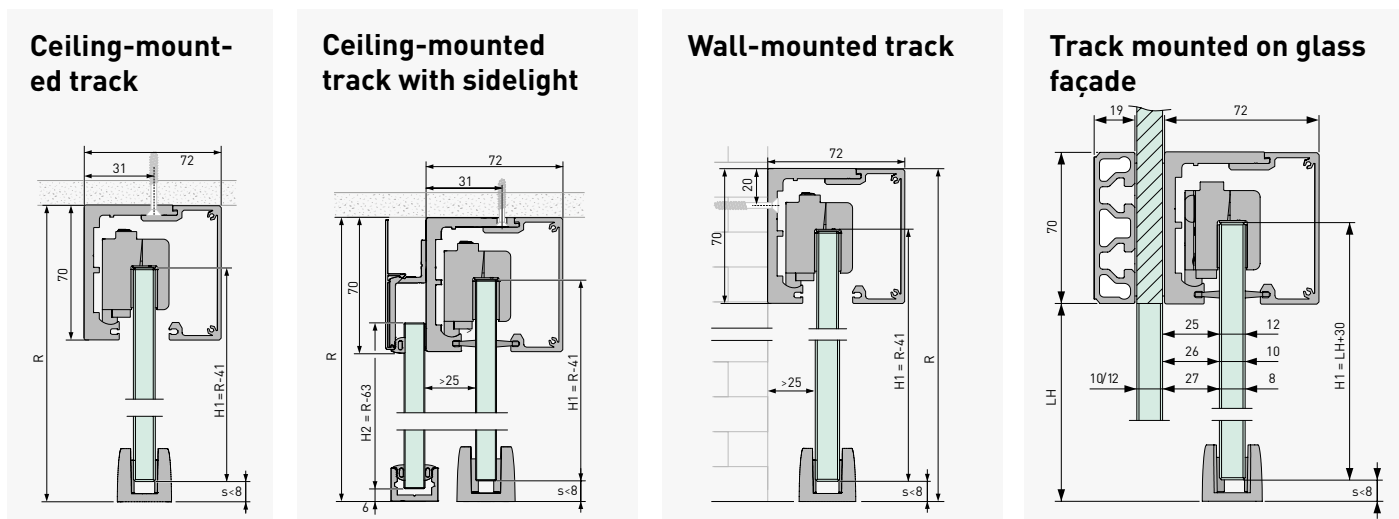

Legend

A	=	glass width of sliding sash
B1	=	glass width of sidelight with symmetric profile overlap on both sides
B, B2	=	glass width of sidelight with asymmetric profile overlap
B0	=	transom light width
C1	=	track length with symmetric profile overlap on both sides
C, C2	=	track length with asymmetric profile overlap
H1	=	glass height of sliding sash
H2	=	glass height of sidelight
LH	=	clear height
LW	=	clear width of wall opening (passage width)
R	=	room height

Systems with one sash with sidelight

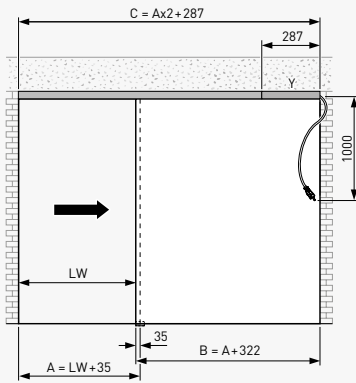

Systems with two sashes with sidelight

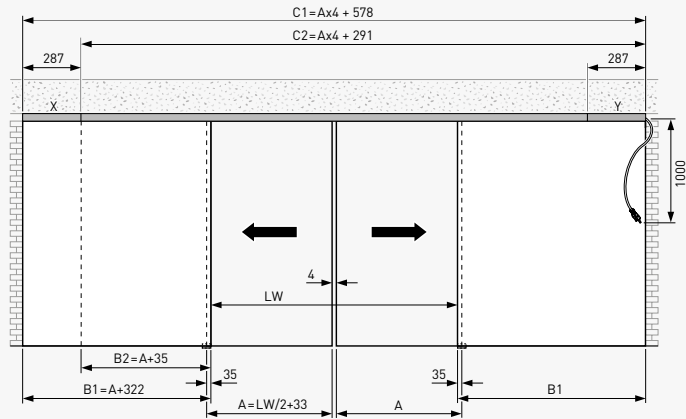

Systems with track mounted on glass façade Clear width 1000 mm

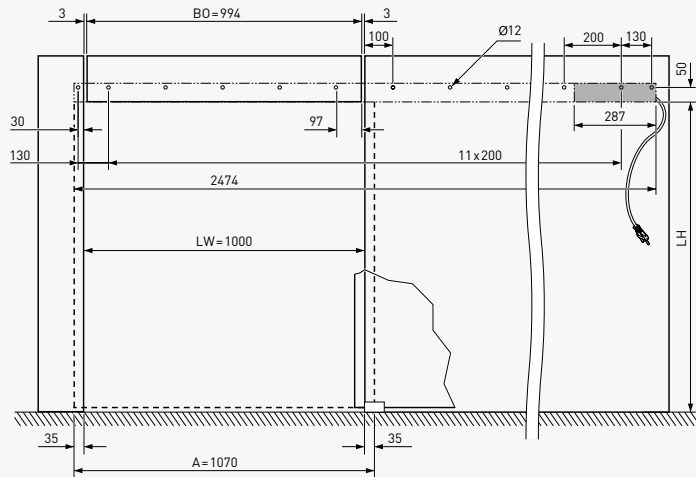

Systems with track mounted on glass façade Clear width 1200 mm

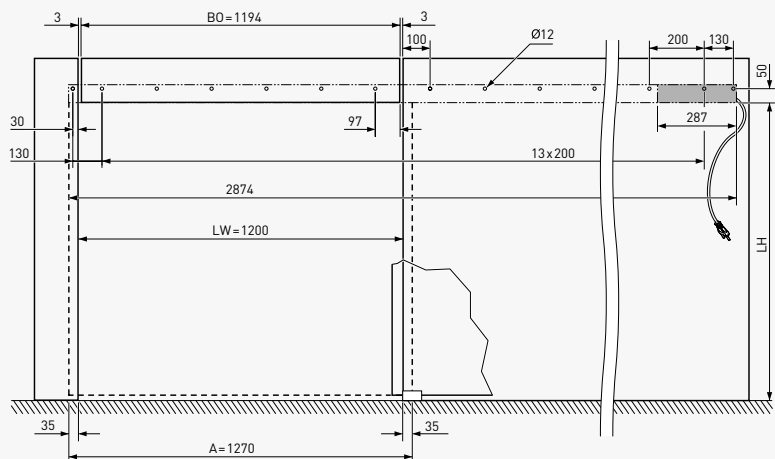



The company

With its Vitris product division, Willach is among the leading producers of glass fittings in Europe. Since its establishment in 1889, the manufacture of products to the highest quality and precision standards has been the supreme dictum of the company. Numerous technical innovations and intelligent solutions that paid close attention to the finest detail meant that Willach cemented its pioneering reputation at an early stage. With the Portavant product line, Willach today offers a range of high quality fittings for glass sliding doors. The Vitris product range also includes a comprehensive modular system of showcase fittings, sliding door locks and slot bar systems for discerning interior, shop and trade show furnishings. Vitris products are certified in accordance with ISO standards and are manufactured at our Ruppichteroth production site in Germany to stringent manufacturing standards. Our approach guarantees excellent quality and consistently high level of availability of the complete Vitris range.

Contact us and let us advise you!

Gebr. Willach GmbH
Stein 2
53809 Ruppichteroth
Germany
Tel.: +49 (0)2295 92 08 -421/-427
Fax: +49 (0)2295 92 08 429
vitris@willach.com
www.willach.com



WillachGroup



Distributor stamp

Product descriptions, drawings and illustrations represent neither assured characteristics nor declarations of guarantee. Subject to change.